

**City of Lathrop
Department of Public Works**

**Well 7 Pump House Improvements
CIP PW 23-05**

CUPCAA Informal Bid Solicitation



Approved: _____

Brad Taylor, P.E., City Engineer

Date: March 13, 2023



CITY OF LATHROP - NOTICE INVITING INFORMAL BIDS
PURSUANT TO STATE OF CALIFORNIA UPCCA ACT

Well 7 Pump House Improvements, CIP PW 23-05

TABLE OF CONTENTS

Bidding and Construction Documents

<u>SECTION</u>	<u>SECTION TITLE</u>
00020	Notice to Contractors
00100	Instructions to Bidders
00300	Bid Proposal Forms
00500	Sample Contract
00610	Performance Bond
00620	Payment (Labor and Materials) Bond
00660	Worker's Compensation Certification
00670	Guaranty
00700	General Conditions
00800	Supplementary Conditions
ATTACHMENT A	Project Plans
ATTACHMENT B	Technical Specifications
ATTACHMENT C	Painting Plan
ATTACHMENT D	Project Location Map



CITY OF LATHROP - NOTICE INVITING INFORMAL BIDS
PURSUANT TO STATE OF CALIFORNIA UPCCA ACT

Well 7 Pump House Improvements, CIP PW 23-05

NOTICE TO CONTRACTORS

The City of Lathrop invites sealed informal bids for the construction of public improvements for the Well 7 Pump House Improvements, Capital Improvement Project PW 23-05, City of Lathrop, California. Sealed bids will be received at the City of Lathrop, located at 390 Towne Centre Drive, Lathrop, CA until **6:00 PM, Thursday, March 30, 2023**. Bids submitted by mail shall be addressed to: City of Lathrop, Attention Senior Construction Manager / SEALED BID FOR CIP PW 23-05: 390 Towne Centre Drive, Lathrop, CA 95330.

A **Pre-Bid Meeting** will be held to allow prospective bidders to examine the Pump House. The Pre-Bid Meeting will be held at **2:00 PM, Thursday, March 16, 2023** at the Well 7 Pump Facility, 15800 5th Street Lathrop, CA 95330.

SCOPE OF WORK

The scope of work to be performed under this contract is generally described as provision of materials, construction of steel and wood roof framing, siding and standing seam steel roof panels for, and painting the interior and exterior of, the City's Well 7 pump house.

BIDDING INFORMATION

The value of this work is estimated at \$74,000 and requires the following bonds at the indicated percentages of contract value: Bid (10%), Payment (100%), Performance (100%) and a Guaranty Bond (10%) at the completion of the project, valid for one year.

A valid California Contractor's license Class B (General Building) is required to bid on this project.

In accordance with SB 854, all contractors who bid or work on Public Works projects for the City of Lathrop are subject to the following requirements:

- **DIR Registration.** Each Bidder submitting a proposal to complete the work, labor, materials and/or services ("Work") subject to this procurement must be a Department of Industrial Relations registered contractor pursuant to Labor Code Section 1725.5 ("DIR Registered Contractor"). A Bidder who is not a DIR Registered Contractor when submitting a proposal for Work is deemed "not qualified" and the proposal of such a Bidder will be rejected as non-responsive. Pursuant to Labor Code Section 1725.5, all Subcontractors identified in a Bidder's Subcontractors' List shall be DIR Registered Contractors. If awarded the Contract for the Work, at all times during performance of the Work, the Bidder and all Subcontractors, of any tier, shall be DIR Registered Contractors.

INQUIRIES

All communication relative to the administration of this work shall be directed to Ken Reed, Senior Construction Manager, at kreed@ci.lathrop.ca.us, (209) 941-7363 or by calling the Public Works Department at (209) 941-7430.

SECTION 00100

WELL 7 PUMP HOUSE IMPROVEMENTS, CIP PW 23-05
CUPCCAA INFORMAL BID SOLICITATION

INSTRUCTIONS TO BIDDERS

INSTRUCTIONS TO BIDDERS

BACKGROUND

The City of Lathrop is located in the San Joaquin Valley, 70 miles east of San Francisco, CA and has an approximate population of 30,000 people. The work will replace or upgrade wall and roof sections of the pump house with more secure and weather-tight materials, provide fresh paint for the pump house interior and exterior and remove outdated appurtenances from the site.

DESCRIPTION OF WORK

The work to be performed under this contract is generally described as, but not necessarily limited to provision of equipment and materials, demolition and offhaul of materials, construction of steel and lumber roof framing, siding and standing seam steel roof panels for, and painting the interior and exterior of, the City's Well 7 pump house. Project Plans, (Attachment A), Technical Specifications (Attachment B), Painting Plan (Attachment C) and Location Map (Attachment D) provide additional project information.

All project materials shall be supplied by the Contractor, and the Work shall be performed in accordance with the Standard Specifications and the Construction Documents as defined in the General Conditions.

The Work shall be complete, and all work, materials, and services not expressly shown or called for in the Construction Documents which may be necessary for the complete and proper construction of the Work in good faith shall be performed, furnished, and installed by the Contractor as though originally specified or shown in said Construction Documents, at no increase in cost to the City.

SITE OF WORK

Bidder is encouraged to attend the Pre-Bid Meeting on at 2:00 PM, Thursday March 16, 2023 at the Well 7 Pump House, and shall not rely solely on the work description. The Well 7 Pump House is located at 15800 5th Street Lathrop, CA 95330.

COMPLETION OF WORK

The Contractor shall commence work under this Contract on or before ten working days after receiving written Notice to Proceed from the City and shall fully **complete all work within 30 working days after the Notice to Proceed**, subject to provisions contained in the Construction Documents relating to extension of time. The Contractor shall, at all times during the continuance of the Contract, prosecute the work with such force and equipment as are sufficient to complete it within the time specified.

BID

Before submitting a Bid, bidders shall carefully examine and read the Construction Documents, visit the site of the work, fully inform themselves as to all existing site conditions and limitations.

SECTION 00100

WELL 7 PUMP HOUSE IMPROVEMENTS, CIP PW 23-05
CUPCCAA INFORMAL BID SOLICITATION

INSTRUCTIONS TO BIDDERS

Bidders are required to inform themselves fully of the conditions relating to performance of the Work, and must employ, as far as possible, such methods and means in carrying out the Work as will not cause any interruption or interference to any other contractor or operations of the City or any other public agency.

Submission of a Bid shall be considered conclusive evidence that the Bidder has fully studied the Construction Documents, that Contractor has examined the site of the work, and that the Bidder is satisfied as to the conditions to be encountered in performing the work and as to the requirements of the Construction Documents.

Bids shall be properly executed upon the Bid form bound herein and made a part of these Construction Documents. All blank spaces in the Bid forms must be filled in, in black or blue ink. Numbers shall be stated both in words and in figures where indicated on the Bid form, and original, 'wet' signatures are required of all persons signing the Bid form. No changes on the Bid forms are allowed. In case of a difference in written words and figures, the amount stated in written words shall govern unless obviously in error.

SUBMISSION OF BIDS

All Bids must be submitted at the place and before the time prescribed in the Notice to Contractors. It is the Bidder's sole responsibility to see that his Bid is received in proper time. Bids received after that time will not be accepted.

Each Bid must be submitted in a non-transparent sealed envelope; if submitted by mail, enclose Bid envelope in another envelope addressed to:

Public Works
Attention: Senior Construction Manager
City of Lathrop
390 Towne Centre Drive
Lathrop, CA 95330

The sealed Bid envelope shall, in the lower right portion, be plainly identified with the following information:

- (a) Do not open before 6:00 PM on Thursday, March 30, 2023
- (b) Bid of: _____ (Name of Bidder) _____, Contractor.
- (c) CIP PW 23-05

INTERPRETATION OF PLANS AND SPECIFICATIONS

If any person contemplating submitting a Bid is in doubt as to the true meaning of any part of the Construction Documents, or finds discrepancies in or omissions from the Construction Documents, he/she may submit to the City's Senior Construction Manager, (as listed in *Section 00020 - Notice to Contractors* of these Specifications) a written request for an interpretation or correction thereof. All written requests must be received a minimum of 72 hours prior to bid

SECTION 00100

WELL 7 PUMP HOUSE IMPROVEMENTS, CIP PW 23-05
CUPCCAA INFORMAL BID SOLICITATION

INSTRUCTIONS TO BIDDERS

opening; requests received after this time will not be accepted. The person submitting the request will be responsible for its prompt delivery. Any interpretation or correction of the Construction Documents will be made only by Addendum duly issued and a copy of such Addendum will be mailed or delivered to each person receiving a set of the Construction Documents. The City will not be responsible for any other explanations or interpretations of the Construction Documents. In the interest of providing information to plan holders quickly, Contractors are encouraged to provide email address(es) to the City.

ADDENDA

Any Addenda issued before the time of bid opening are deemed to be made a part of the Construction Documents.

MODIFICATION AND WITHDRAWAL OF BIDS

No modification of bids will be allowed. Any bidder may withdraw its bid, either personally or by telegraphic or written request, if such request is received by the Senior Construction Manager prior to the scheduled time for bid opening. Any bid so withdrawn may not be resubmitted.

Bids delivered to the Project Manager at the time set for opening shall be irrevocable, and no bidder may withdraw its bid for a period of 60 days after the date of the opening of bids.

BIDDERS INTERESTED IN MORE THAN ONE BID

No Bidder, whether a person, firm, partnership, corporation, or association, shall be allowed to make, file, or to be interested in more than one Bid for the same work unless alternate bids are called for. A person, firm, partnership, corporation, or association who has submitted a sub bid to a Bidder, or who has quoted prices on materials to a Bidder, is not thereby disqualified from submitting a sub bid or quoting prices to other Bidders.

DISQUALIFICATION OF BIDDERS

More than one Bid for the same work from a person, firm, partnership, corporation, or association under the same or different name will not be accepted. Reasonable ground for believing that any person, firm, partnership, corporation, or association is interested in more than one Bid for the same work will cause the rejection of all Bids for the work in which such Bidder is interested. Any or all Bids will be rejected if there is reason for believing that collusion exists among any of the Bidders.

EXPERIENCE OF BIDDERS

Each Bid shall be supported by a statement of the Bidders' experience on the form entitled "INFORMATION REQUIRED OF BIDDER," bound herein.

SECTION 00100

WELL 7 PUMP HOUSE IMPROVEMENTS, CIP PW 23-05
CUPCCAA INFORMAL BID SOLICITATION

INSTRUCTIONS TO BIDDERS

CONTRACTOR'S LICENSE CLASSIFICATION

In accordance with the provisions of California Public Contract Code Section 3300, the City of Lathrop has determined that the Contractor must possess a valid Class "B" (General Building) Contractor's license at the time of bid submission and maintain said license throughout completion of work necessary if awarded bid. Failure to possess the specified license shall render the Bid as non-responsive and shall act as a bar to award of the Contract to any bidder not possessing said license at the time of bid submission.

BIDDER'S STATEMENT OF SUBCONTRACTORS

In the form entitled List of Subcontractors, in the Information Required of Bidder and pursuant to Section 4107 of the Public Contract Code, the Bidder shall submit the name and location of the place of business of each subcontractor who will perform work or labor or render service to the Bidder in or about the construction of the Work or improvement, or a subcontractor licensed by the State of California who under subcontract to the Bidder specially fabricates and installs a portion of the work, in an amount in excess of one-half of one percent (1/2%) of the Bid. The Bidder shall indicate the portion which will be done by each such subcontractor for each such portion as is defined by the subcontractor in its bid. This listing requirement shall apply to sub-subcontractors of any installation subcontractor which is utilized to install the Work, which sub-subcontractors perform work in excess of one-half of one percent of the Contractor's Total Bid Price. The Contractor shall ensure by Contract that any subcontractor installing the Work fulfills the responsibilities of a prime contractor under Public Contract Code Section 4100, et. seq.

Failure to so list subcontractors is an express statement by the Bidder that it will perform that portion of the work with its own forces. The Bidder may not substitute any person or subcontractor for a listed subcontractor without first obtaining written permission of the Senior Construction Manager pursuant to provisions of Section 4107 of the Public Contract Code.

CALIFORNIA WAGE RATE REQUIREMENTS

In accordance with the provisions of California Labor Code Sections 1770, 1773, 1773.1, 1773.6 and 1773.7 as amended, the Director of the Department of Industrial Relations has determined the general prevailing rate of per diem wages in accordance with the standards set forth in Section 1773 for the locality in which the Work is to be performed. A copy of said wage rates is on file at the office of the City of Lathrop and shall be made available to any interested party on request. It shall be mandatory upon the Contractor to whom the Work is awarded and upon any subcontractor under the Contractor to pay not less than said specified rates to all workers employed by them in the execution of the Work.

DEPARTMENT OF INDUSTRIAL RELATIONS- COMPLIANCE MONITORING UNIT

DIR Registration.

Contractor and Subcontractor Compliance. Strict compliance with DIR registration requirements pursuant to Labor Code Section 1725.5 is a material obligation of the

SECTION 00100

Contractor under the Contract Documents. The foregoing includes without limitation, compliance with DIR Registration requirements at all times during performance of the Work by the Contractor and all Subcontractors of any tier. The failure of the Contractor and all Subcontractors, of every tier, to be DIR registered at all times during the performance of the Work is the Contractor's default of a material obligation of the Contractor under the Contract Documents.

No Subcontractor Performance of Work without DIR Registration. No portion of the Work is permitted to be performed by a Subcontractor of any tier unless the Subcontractor is a DIR Registered contractor.

Contractor Obligation to Verify Subcontractor DIR Registration Status. An affirmative and on-going obligation of the Contractor under the Contract Documents is the Contractor's verification that all Subcontractors, of all tiers, are at all times during performance of Work in full and strict compliance with DIR Registration requirements. The Contractor shall not permit or allow any Subcontractor of any tier to perform any Work without the Contractor's verification that all such Subcontractors are in full and strict compliance with DIR Registration requirements.

Contractor Obligation to Request Substitution of Non-DIR Registered Subcontractor. If any Subcontractor identified in the Contractor's Subcontractor List submitted with the Contractor's proposal for the Work is not DIR Registered at the time of opening of proposals for the Work or if a Subcontractor's DIR registration lapses prior to or during a Subcontractor's performance of Work, the Contractor shall request the CITY's consent to substitute the non-DIR registered Subcontractor pursuant to Labor Code Section 1771.1(c)(3) and/ or Labor Code Section 1771.1(d).

Certified Payroll Records.

Compliance with Labor Code Section 1771.4 and 1776. A material obligation of the Contractor under the Contract Documents is: (i) the Contractor's strict compliance with the requirements pursuant to Labor Code Section 1771.4 and 1776 for preparation and submittal of Certified Payroll Records ("CPR"); and (ii) the Contractor's enforcement of CPR preparation and submittal for all Subcontractors of every tier.

Express Condition Precedent to Payment of Contract Price. Strict compliance with CPR requirements established pursuant to Labor Code Section 1776 is an express condition precedent to the CITY's obligation to: (i) process any request for payment of any portion of the Contract Price; or (ii) to disburse any portion of the Contract Price to the Contractor. The Contractor shall demonstrate strict compliance with CPR preparation and submittal requirements by delivery to the CITY of electronic files or hard copies of all CPR's submitted by the Contractor and/ or Subcontractors for Work pursuant to Labor Code Section 1771.4 and 1776 concurrently with the submittal thereof to the Labor Commissioner. The CITY: (i) shall not be obligated to process or disburse any portion of the Contract Price; or (ii) shall not be deemed in default of the CITY's obligations under

SECTION 00100

the Contract Documents unless the Contractor's demonstrates strict compliance with CPR preparation and submittal requirements.

Prevailing Wage Rate (PWR) Monitoring and Enforcement. During the Work, pursuant to Labor Code Section 1771.4(a)(4), the Department of Industrial Relations shall monitor and enforce the obligation of the Construction and Subcontractors of every tier to pay the laborers performing any portion of the work the PWR established for the classification of work/ labor performed.

AWARD OF CONTRACT

Award of the Contract will be made only to Responsive Responsible Bidders possessing the ability to perform successfully, which will be determined by considering such matters as Contractor integrity, compliance with public policy, record of past performance, and financial and technical resources.

Award of the contract shall be made to the responsive responsible bidder whose bid, conforming with all the material terms and conditions of the invitation for bids, is the lowest total bid shown in the bid schedule. Any challenge or contest of competing bids by Bidders must be submitted to the Senior Construction Manager in writing within 3 days from the date of bid opening.

The City of Lathrop hereby notifies all bidders that it will affirmatively ensure that in any contract entered into pursuant to this advertisement, disadvantaged businesses including minority and woman owned business enterprises will be afforded full opportunity to submit bids in response to this invitation and will not be discriminated against on the grounds of race, color, or national origin in consideration for an award.

Pursuant to Public Contract Code Section 1103, "Responsive Responsible Bidder" means a bidder who has demonstrated the attribute of trustworthiness, as well as quality, fitness, capacity, and experience to satisfactorily perform the public works contract.

BID SECURITY, BONDS AND INSURANCE

Each Bid shall be accompanied by a certified or cashier's check or an approved Bid Bond in the amount of ten percent (10%) of the Total Bid Price payable to the City of Lathrop. Said check or bond shall be made payable to the City and shall be given as a guarantee that the Bidder, if awarded the work, will enter into a Contract with the City, and will furnish the necessary insurance certificates, Payment Bond, Performance Bond and Maintenance (Guaranty) Bond; each of said bonds to be in the amounts stated below. In case of refusal or failure to enter into said Contract, the check or Bid Bond, as the case may be, shall be forfeited to the City. If the Bidder elects to furnish a Bid Bond as its Bid security, the Bidder shall use the Bid Bond form bound herein, or one conforming substantially to it in form.

The successful bidder shall furnish a Performance Bond (100%), Payment Bond (100%) and Guaranty Bond (10%) of contract price.

SECTION 00100

WELL 7 PUMP HOUSE IMPROVEMENTS, CIP PW 23-05
CUPCCAA INFORMAL BID SOLICITATION

INSTRUCTIONS TO BIDDERS

The Bond Company acknowledges that the Performance Bond, Payment Bond, and Maintenance (Guaranty) Bond will be separately enforceable until each is separately released by the City of Lathrop. The release of one bond shall not release the remaining bond(s), even if all bonds share the same bond number.

LATHROP CITY COUNCIL RIGHTS RESERVED

The City of Lathrop reserves the right to accept or reject any or all Bids, to waive any irregularity in a Bid, and to make award to the lowest responsive, responsible Bidder as it may best serve the interest of the City of Lathrop.

EXECUTION OF CONTRACT

The form of Contract, which the successful Bidder as Contractor will be required to execute, is included in the Contract Documents of these Specifications, and should be carefully examined by the Bidder. The Contract will be executed in two original counterparts.

The successful Bidder shall execute and return all original Contract Documents to the Project Manager within 10 calendar days after receipt of the Notice of Award.

The successful Bidder shall also secure all required bonds and insurance and furnish such bonds and certificates of insurance and endorsements indicating proof of coverage, and complete the Guaranty simultaneously with execution of the Contract.

RETAINAGE FROM PAYMENTS

The Contractor may elect to receive 100 percent of payments due under the Construction Documents from time to time, without retention of any portion of the payment by the City of Lathrop, by depositing securities of equivalent value with the City of Lathrop or escrow agent, all in accordance with the provisions of Section 22300 of the Public Contract Code. Such securities, if deposited by the Contractor, shall be valued by the City of Lathrop, whose decision on valuation of the securities shall be final. Securities eligible for Investment under this provision shall include those listed in Section 16430 of the Government Code, bank or savings and loan certificates of deposit, interest bearing demand deposit accounts, standby letters of credit, or other security agreed to by City of Lathrop and Contractor.

LIQUIDATED DAMAGES

If the Contractor fails to complete the Work within the time specified for Substantial Completion in the Contract, then the Contractor does hereby agree, as a part consideration for the awarding of this Contract, to pay to the City, as liquidated damages and not as a penalty, the sum of \$100 per each working day beyond the dates set forth in the Agreement that the Contractor fails to achieve Substantial Completion for the Project. The said amount is fixed and agreed on by and between the Contractor and the City because of the impracticability and extreme difficulty of fixing and ascertaining the true value of the damages that the City will sustain by failure of the Contractor to complete the Work on time, including damages, some of which are indefinite. Said amount is agreed to be a reasonable estimate of the amount of damages which the City will sustain and said

SECTION 00100

**WELL 7 PUMP HOUSE IMPROVEMENTS, CIP PW 23-05
CUPCAA INFORMAL BID SOLICITATION**

INSTRUCTIONS TO BIDDERS

amount shall be deducted from any monies due or that may become due to the Contractor, and if said monies are insufficient to cover said damages, then the Contractor shall pay the amount of the difference.

(END OF SECTION)

SECTION 00300

WELL 7 PUMP HOUSE IMPROVEMENTS, CIP PW 23-05
CUPCCAA INFORMAL BID SOLICITATION

BID PROPOSAL FORMS

BID PROPOSAL FORMS

TO: City of Lathrop
390 Towne Centre Drive
Lathrop, CA 95330

ATTENTION: Public Works Department

FOR: **WELL 7 PUMP HOUSE IMPROVEMENTS, CIP PW 23-05**

THE UNDERSIGNED, AS BIDDER, HEREBY AGREES AND DECLARES THAT:

LEGAL COMPLIANCE

The only persons or parties interested in this Bid as Principals are those named herein; that this Bid is made without collusion with any other person, firm, partnership, corporation, or association; that he has carefully examined the location of the proposed work and the Construction Documents; and he proposes and agrees that if this Bid is accepted he will contract with the City of Lathrop, in the form of the Contract as set forth in the Construction Documents for said project, to provide all the necessary labor, services, materials, and equipment, and to do all the work and furnish all the materials; and that he will accept in full payment therefore the price as proposed in the following Bid Schedule.

SCHEDULE OF PRICES

All applicable permit fees, licensing costs, sales taxes, State, and/or Federal, and any other taxes, patent rights, or royalties are included in the prices quoted in the Bid. All blank spaces must be filled in.

BASIS OF AWARD

The basis for award of the contract will be the total price of the bid. The City of Lathrop reserves the right to award only the work contemplated by the bid or none of the work.

SECTION 00300WELL 7 PUMP HOUSE IMPROVEMENTS, CIP PW 23-05
CUPCAA INFORMAL BID SOLICITATION

BID PROPOSAL FORMS

WELL 7 PUMP HOUSE IMPROVEMENTS, CIP PW 23-05**BID SCHEDULE**

BID ITEM	DESCRIPTION	QUANTITY	UNITS	UNIT PRICE	EXTENDED TOTAL
1	Removal, Offhaul and Disposal of All Pump House Building Materials and Fencing as Indicated on Plans	1	LS		
2	Mobilization	1	LS		
3	Repair Damage to Underlayment in Multiple Locations	1	LS		
4	Construct New Roof Section Including Framing to Match Existing	77	SF		
5	Install Roof Moisture Barrier on All New Roofing	200	SF		
6	Construct Removable Roof Hatch including Framing	1	LS		
7	Install Standing Seam Roof Panels	430	SF		
8	Re-side Exterior of North Wall	70	SF		
9	Construct Well Access Door	1	EA		
10	Paint Exterior of Building, Diesel Tank, Piping as Shown on Painting Plan	1	LS		

SECTION 00300

**WELL 7 PUMP HOUSE IMPROVEMENTS, CIP PW 23-05
CUPCAA INFORMAL BID SOLICITATION**

BID PROPOSAL FORMS

11	Paint Interior Wall Surfaces	1	LS		
12	Replace "WELL 7" Facility Name Sign and Address Numbers	1	LS		
13	Remove Antenna Conduit From Service Panel and Repair Roof	1	LS		

TOTAL BID: \$ _____

TOTAL BID IN WORDS: _____

SECTION 00300

INFORMATION REQUIRED OF BIDDER

The Bidder (Contractor) shall furnish the following information. This information is considered essential in enabling the Project Manager to determine if the Bidder is experienced in similar types of work and if the Bid is based on a careful study of methods applicable to the work and full realization of the various factors which may affect the progress of the work. Failure to comply with this requirement may render the Bid non-responsive and may cause its rejection. Additional sheets shall be attached as required.

BIDDER'S INFORMATION

- (1) Bidder's name and address:

- (2) Bidder's telephone number: _____
- (3) Bidder's fax number: _____
- (4) Bidder's Contractor's License (Class): _____
License No.: _____
Expires: _____
- (5) Person who inspected site of proposed work for Contractor's firm:
Name: _____ Date of Inspection: _____
- (6) List 3 projects of a nature similar to this project:

Project	Contract Price	Name, Address and Telephone Number of Owner

SECTION 00300

List of Subcontractors:

The Bidder shall list below the name and business address of each subcontractor who will perform work under this Bid in excess of one-half of one percent of the Contractor's Total Bid Price, and shall also list the portion of the WORK which will be done by such subcontractor, in accordance with Section 4107 of the Public Contract Code. After the opening of bids, no changes or substitutions will be allowed except as otherwise provided by law. The listing of more than one subcontractor for each item of work to be performed with the words "and/or" will not be permitted. Failure to comply with this requirement may render the Bid non-responsive and may cause its rejection. Should the Contractor provide a bid that does not require a subcontractor, the Contractor shall note that on this page by writing "Not Applicable" in the list below.

<u>Work to be Performed</u>	<u>Subcontractor License Number</u>	<u>Percent of Total Contract</u>	<u>Subcontractor's Name & Address</u>
1. _____	_____	_____	_____ _____
2. _____	_____	_____	_____ _____
3. _____	_____	_____	_____ _____
4. _____	_____	_____	_____ _____
5. _____	_____	_____	_____ _____
6. _____	_____	_____	_____ _____

Note: Attach additional sheets if required.

SECTION 00300

WELL 7 PUMP HOUSE IMPROVEMENTS, CIP PW 23-05
CUPCAA INFORMAL BID SOLICITATION

BID PROPOSAL FORMS

ADDENDA

Bidder acknowledges receipt of the following addendum (addenda):

Respectfully submitted,

Dated

Legal Name of Firm

Signature of Authorized Representative

(Seal)

(If Bidder is a corporation, show State in which incorporated.)

The full names and post office addresses of all persons and parties interested in the foregoing Bid as principals are as follows:

(NOTICE): Give first and last names in full; in case of corporation, give names of President, Secretary, Treasurer, and Manager, and in case of partnerships and joint ventures, give names and Post Office addresses of all the individual members.

SECTION 00300

WELL 7 PUMP HOUSE IMPROVEMENTS, CIP PW 23-05
CUPCCAA INFORMAL BID SOLICITATION

BID PROPOSAL FORMS

BIDDER'S BOND

KNOW ALL MEN BY THESE PRESENTS:

THAT WE _____

as PRINCIPAL, and _____

as SURETY are held; and firmly bond unto the City of Lathrop in the penal sum of TEN PERCENT (10%) OF THE TOTAL AMOUNT OF THE BID of the Principal above named, submitted by the Principal to the City of Lathrop for the work described below, for the payment of which sum in lawful money of the United States, well and truly to be made to the City of Lathrop to which the bid was submitted, we bind ourselves, our heirs, executors, administrators and successors, jointly and severally, firmly by those presents. In no case shall the liability of the surety hereunder exceed the sum of \$ _____.

THE CONDITION OF THIS OBLIGATION IS SUCH,

THAT, WHEREAS, the Principal has submitted the above mentioned bid to the City of Lathrop for certain construction specifically described as follows, for which bids are to be opened at the Public Works Department, 390 Towne Centre Drive, Lathrop, CA: **WELL 7 PUMP HOUSE IMPROVEMENTS, CIP PW 23-05.**

NOW, THEREFORE, if the Principal is awarded the contract and within the time and manner required under the specifications, after the prescribed forms are presented to him for signature enters into a written contract in the prescribed form, in accordance with the bid, and files two bonds with the City, one to guarantee faithful performance, and the other to guarantee payment for labor and materials as required by law, then this obligation shall be null and void; otherwise, it shall be and remain in full force.

SECTION 00300

**WELL 7 PUMP HOUSE IMPROVEMENTS, CIP PW 23-05
CUPCAA INFORMAL BID SOLICITATION**

BID PROPOSAL FORMS

IN WITNESS WHEREOF, we have hereunto set our hands and seals on this _____ day
of _____, 20__.

_____ (Seal)

_____ (Seal)

_____ (Seal)

_____ (Seal)

Address: _____

Address: _____

NOTE: Signatures of those executing for the surety must be properly acknowledged.

SECTION 00300

WELL 7 PUMP HOUSE IMPROVEMENTS, CIP PW 23-05
CUPCCAA INFORMAL BID SOLICITATION

BID PROPOSAL FORMS

NONCOLLUSION AFFIDAVIT

STATE OF _____)
) ss.
COUNTY OF _____)

_____, being first duly sworn, deposes and says that he or she is

_____ of _____ the party making the foregoing bid that the bid is not made in the interest of, or on behalf of, any undisclosed person, partnership, company, association, organization, or corporation; that the bid is genuine and not collusive or sham; that the bidder has not directly or indirectly induced or solicited any other bidder to put in a false or sham bid, and has not directly or indirectly colluded, conspired, connived, or agreed with any bidder or anyone else to put in a sham bid, or that anyone shall refrain from bidding; that the bidder has not in any manner, directly or indirectly, sought by agreement, communication, or conference with anyone to fix the bid price of the bidder or any other bidder, or of that of any other bidder, or to secure any advantage against the public body awarding the contract of anyone interested in the proposed contract; that all statements contained in the bid are true; and, further, that the bidder has not, directly or indirectly, submitted his or her bid price or any breakdown thereof, or the contents thereof, or divulged information or data relative thereto, or paid, and will not pay, any fee to any corporation, partnership, company associated, organization, bid depository, or to any member or agent thereof to effectuate a collusive or sham bid.

Signature of: President, Secretary,
Manager, Project Manager or Representative

The County of _____

State of _____

Subscribed and sworn to (or affirmed) before me

on this _____ day of _____, 20____, by

_____, proved to me on the basis of satisfactory evidence to be the person(s) who appeared before me.

Seal _____

Signature _____

SECTION 00300

PUBLIC CONTRACT CODE SECTION 10162 QUESTIONNAIRE

In accordance with Public Contract Code Section 10162, the Bidder shall complete, under penalty of perjury, the following questionnaire:

Has the Bidder, any officer of the Bidder, or any employee of the Bidder, who has a proprietary interest in the Bidder, ever been disqualified, removed, or otherwise prevented from bidding on, or completing a federal, state, or local government project because of a violation of law or a safety regulation?

Yes _____ No _____

If the answer is yes, explain the circumstances in the following space.

PUBLIC CONTRACT SECTION 10232 STATEMENT

In accordance with Public Contract Code Section 10232, the Contractor hereby states under penalty of perjury, that no more than one final unappealable finding of contempt of court by a federal court has been issued against the Contractor within the immediately preceding two year period because of the Contractor's failure to comply with an order of a federal court which orders the Contractor to comply with an order of the National Labor Relations Board.

NOTE: The above Statement and Questionnaire are part of the Proposal. Signing this proposal on the signature portion thereof shall also constitute signature of this Statement and Questionnaire.

Bidders are cautioned that making a false certification may subject the certifier to criminal prosecution.

(END OF SECTION)

SECTION 00500

CONTRACT

This Contract, dated April 10, 2023 is entered into by and between the City of Lathrop, a municipal corporation of the State of California (City), and _____, (Contractor), whose Taxpayer Identification Number is _____.

For and in consideration of the following covenants, terms and conditions, City and Contractor (the parties) agree:

- 1. Term. This Contract shall commence on, and be binding on the parties on, the date of execution of this Contract, and shall expire on the date of recordation of the Notice of Substantial Completion, or, if no such notice is required to be filed, on the date that final payment is made hereunder, subject to the earlier termination of this Contract.
- 2. General Scope of Project and Work. Construction Documents for **Well 7 Pump House Improvements, CIP PW 23-05** (Project). Contractor shall furnish labor, services, materials and equipment in connection with the construction of the Project and complete the Work in accordance with the covenants, terms and conditions of this Contract to the satisfaction of City.

The work to be performed under this contract includes all work contained in the Construction Documents, as detailed in Paragraph 3 below, including, but not limited to provision of materials, construction of steel and wood roof framing, siding and standing seam steel roof panels for, and painting the interior and exterior of, the City’s Well 7 pump house, and any task necessary to accomplish the aforementioned tasks.

The work shall be **completed within 30 working days** following issuance of Notice to Proceed.

The Work shall be complete, and all appurtenant work, materials, and services not expressly shown or called for in the Construction Documents which may be necessary for the complete and proper construction of the Work in good faith shall be performed, furnished, and installed by the Contractor as though originally specified or shown. The Contractor will be compensated for actual work performed in accordance with the unit prices and provisions contained in these Construction Documents.

Base Bid Total: \$ _____ (Written Price)

- 3. Construction Documents. This Contract shall include the Construction Documents which are on file with the Public Works Department and are hereby incorporated by reference (i.e. Project Specifications, Project Plans, addenda, certification of insurance, workers compensation certification, and guaranty) and the Bid Documents submitted by _____ on March 30, 2023. For the purposes of construing, interpreting and resolving inconsistencies between the provisions of this Contract, these documents and the provisions thereof are set forth in the order of precedence described in Article 3 of the General Conditions.

SECTION 00500

4. Compensation. In consideration of Contractor's performance of its obligations hereunder, City shall pay to Contractor the amount set forth in Contractor's Bid in accordance with the provisions of this Contract and upon the receipt of written invoices and all necessary supporting documentation within the time set forth in the Construction Documents. Contractor hereby shall not be permitted to invoice the City nor accept compensation for work not yet complete. In no event, shall the Contractor be entitled to payment for work not included in the approved scope of work, a written task order, or change order signed by the City's Public Works Director prior to commencement of any work.
5. Insurance. On or before the Date of Execution, Contractor shall obtain and maintain the policies of insurance coverage described in Section 5.2 of the General Conditions on terms and conditions and in amounts as may be required by the City. City shall not be obligated to take out insurance on Contractor's personal property or the personal property of any person performing labor or services or supplying materials or equipment under the Project. Contractor shall furnish City with the certificates of insurance and with original endorsements affecting coverage required under this Contract on or before the Date of Execution. The certificates and endorsements for each insurance policy shall be signed by a person who is authorized by that insurer to bind coverage in its behalf. Proof of insurance shall be mailed to the Project Manager to the address set forth in Section 15 of this Contract.
6. Indemnification. Contractor agrees to protect, defend, indemnify and hold City, its City Council members, officers, employees, engineer, and construction manager harmless from and against any and all claims, demands, liabilities, losses, damages, costs, expenses, liens, penalties, suits, or judgments, arising in whole or in part, directly or indirectly, at any time from any injury to or death of persons or damage to property as a result of the willful or negligent act or omission of Contractor, or which results from Contractor's noncompliance with any Law respecting the condition, use, occupation or safety of the Project site, or any part thereof, or which arises from Contractor's failure to do anything required under this Contract or for doing anything which Contractor is required not to do under this Contract, or which arises from conduct for which any Law imposes strict liability on Contractor in the performance of or failure to perform the terms and conditions of this Contract, except as may arise from the sole willful or negligent act or omission of City or any of its City Council members, officers, employees. This indemnification shall extend to any and all claims, demands, or liens made or filed by reason of any construction, renovation, or remodeling work performed by Contractor under this Contract at any time during the term of this Contract, or arising thereafter.
7. Assumption of Risk. Contractor agrees to voluntarily assume any and all risk of loss, damage, or injury to the property of Contractor which may occur in, on, or about the Project site at any time and in any manner, excepting such loss, injury, or damage as may be caused by the sole willful or negligent act or omission of City or any of its City Council members, officers, or employees.
8. Waiver. The acceptance of any payment or performance, or any part thereof, shall not operate as a waiver by City of its rights under this Contract. A waiver by City of any breach of any part or provision of this Contract by Contractor shall not operate as a waiver or

SECTION 00500

continuing waiver of any subsequent breach of the same or any other provision, nor shall any custom or practice which may arise between the parties in the administration of any part or provision of this Contract be construed to waive or to lessen the right of City to insist upon the performance of Contractor in strict compliance with the covenants, terms and conditions of this Contract.

9. Compliance with Laws. Contractor shall comply with all Laws now in force or which may hereafter be in force pertaining to the Project and Work and this Contract, with the requirement of any bond or fire underwriters or other similar body now or hereafter constituted, with any discretionary license or permit issued pursuant to any Law of any public agency or official as well as with any provision of all recorded documents affecting the Project site, insofar as any are required by reason of the use or occupancy of the Project site, and with all Laws pertaining to nondiscrimination and affirmative action in employment and hazardous materials.

DEPARTMENT OF INDUSTRIAL RELATIONS- COMPLIANCE MONITORING UNIT

DIR Registration.

- a) **Contractor and Subcontractor Compliance.** Strict compliance with DIR registration requirements pursuant to Labor Code Section 1725.5 is a material obligation of the Contractor under the Contract Documents. The foregoing includes without limitation, compliance with DIR Registration requirements at all times during performance of the Work by the Contractor and all Subcontractors of any tier. The failure of the Contractor and all Subcontractors of every tier to be DIR registered at all times during the performance of the Work is the Contractor's default of a material obligation of the Contractor under the Contract Documents.
- b) **No Subcontractor Performance of Work Without DIR Registration.** No portion of the Work is permitted to be performed by a Subcontractor of any tier unless the Subcontractor is a DIR Registered contractor.
- c) **Contractor Obligation to Verify Subcontractor DIR Registration Status.** An affirmative and on-going obligation of the Contractor under the Contract Documents is the Contractor's verification that all Subcontractors, of all tiers, are at all times during performance of Work in full and strict compliance with DIR Registration requirements. The Contractor shall not permit or allow any Subcontractor of any tier to perform any Work without the Contractor's verification that all such Subcontractors are in full and strict compliance with DIR Registration requirements.
- d) **Contractor Obligation to Request Substitution of Non-DIR Registered Subcontractor.** If any Subcontractor identified in the Contractor's Subcontractor List submitted with the Contractor's proposal for the Work is not DIR Registered at the time of opening of proposals for the Work or if a Subcontractor's DIR registration lapses prior to or during a Subcontractor's performance of Work, the Contractor shall request the CITY's consent to

SECTION 00500

substitute the non-DIR registered Subcontractor pursuant to Labor Code Section 1771.1(c)(3) and/ or Labor Code Section 1771.1(d).

Certified Payroll Records

- a) Compliance with Labor Code Section 1771.4 and 1776. A material obligation of the Contractor under the Contract Documents is: (i) the Contractor's strict compliance with the requirements pursuant to Labor Code Section 1771.4 and 1776 for preparation and submittal of Certified Payroll Records ("CPR"); and (ii) the Contractor's enforcement of CPR preparation and submittal for all Subcontractors of every tier.
- b) Express Condition Precedent to Payment of Contact Price. Strict compliance with CPR requirements established pursuant to Labor Code Section 1776 is an express condition precedent to the CITY's obligation to: (i) process any request for payment of any portion of the Contract Price; or (ii) to disburse any portion of the Contract Price to the Contractor. The Contractor shall demonstrate strict compliance with CPR preparation and submittal requirements by delivery to the CITY of electronic files or hard copies of all CPR's submitted by the Contractor and/ or Subcontractors for Work pursuant to Labor Code Section 1771.4 and 1776 concurrently with the submittal thereof to the Labor Commissioner. The CITY: (i) shall not be obligated to process or disburse any portion of the Contract Price; or (ii) shall not be deemed in default of the CITY's obligations under the Contract Documents unless the Contractor's demonstrates strict compliance with CPR preparation and submittal requirements.
- c) PWR Monitoring and Enforcement. During the Work pursuant to Labor Code Section 1771.4(a)(4), the Department of Industrial Relations shall monitor and enforce the obligation of the Construction and Subcontractors of every tier to pay the laborers performing any portion of the work the PWR established for the classification of work/ labor performed.

RECORD OF WAGES PAID: INSPECTION

Pursuant to Labor Code section 1776, Contractor stipulates the following:

- a) Contractor and each subcontractor shall keep an accurate payroll record, showing the name, address, social security number, work classification, straight time and overtime hours worked each day and week, and the actual per diem wages paid to each journeyman, apprentice, worker, or other employee employed by him or her in connection with the public work under the Facilities lease and Construction Provisions. Such records shall be on forms provided by the Division of Labor Standards Enforcement or shall contain the same information of such forms. The payroll records may consist of payroll data that are maintained as computer records, if printouts contain the same information as the forms provided by the division and the printouts are verified as specified in subdivision (a) of Labor Code section 1776.

SECTION 00500

- b) The payroll records enumerated under subdivision (a) shall be certified and shall be available for inspection at all reasonable hours at the principal office of Contractor on the following basis:
- (1) A certified copy of an employee's payroll record shall be made available for inspection or furnished to such employees or his or her authorized representative on request.
 - (2) A certified copy of all payroll records enumerated in subdivision (a) shall be made available for inspection or furnished upon request to a representative of the CITY, the Division of Labor Standards Enforcement, and Division of Apprenticeship Standards of the Department of Industrial Relations.
 - (3) A certified copy of all payroll records enumerated in subdivision (a) shall be made available upon request by the public for inspection or copies thereof. However, a request by the public shall be made through either the CITY, the Division of Apprenticeship Standards, or the Division of Labor Standards Enforcement. If the requested payroll records have not been provided pursuant to paragraph (2), the requesting party shall, prior to being provided the records, reimburse the costs of preparation by Contractor, subcontractors, and the entity through which the request was made. The public shall not be given access to such records at the principal office of Contractor.
- c) Contractor shall file a certified copy of the records enumerated in subdivision (a) with the entity that requested such records within ten (10) days after receipt of the written request.
- d) Any copy of records made available for inspection as copies and furnished upon request to the public or any public agency, by the CITY, the Division of Apprenticeship Standards, or the division of Labor Standards Enforcement shall be marked or obliterated in such a manner as to prevent disclosure of an individual's name, address and social security number. The name and address of contractor awarded the contract or performing the contract shall not be marked or obliterated.
- e) Contractor shall inform the CITY of the location of the records enumerated under subdivision (a), including the street address, city, and county, and shall, within (5) working days, provide a notice of a change of location and address.
- f) In the event of noncompliance with the requirements of this Article, Contractor shall have ten (10) days in which to comply subsequent to receipt of written notice specifying in what respects Contractor must comply with this Article. Should noncompliance still be evident after such 10-day period, Contractor shall pay a penalty of One- Hundred Dollars (\$100.00) to the CITY for each calendar day, or portion thereof, for each worker, until strict compliance is effectuated. Upon the request of the Division of Apprenticeship Standards or the Division of Labor Standards Enforcement, such penalties shall be withheld from the progress payment then due.

SECTION 00500

The responsibility for compliance with this Article shall rest upon Contractor.

10. Bonds. As a condition precedent to City's obligation to pay compensation to Contractor, and on or before the date of Execution, Contractor shall furnish to the Project Manager the Bonds as required under Section 00700 - 5.1A.
11. Representations and Warranties. In the supply of any materials and equipment and the rendering of labor and services during the course and scope of the Project and Work, Contractor represents and warrants:
 - (1) Any materials and equipment which shall be used during the course and scope of the Project and Work shall be vested in Contractor;
 - (2) Any materials and equipment which shall be used during the course and scope of the Project and Work shall be merchantable and fit to be used for the particular purpose for which the materials are required;
 - (3) Any labor and services rendered and materials and equipment used or employed during the course and scope of the Project and Work shall be free of defects in workmanship for a period of one (1) year after the recordation of the Notice of Substantial Completion, or, if no such notice is required to be filed, on the date that final payment is made hereunder;
 - (4) Any manufacturer's warranty obtained by Contractor shall be obtained or shall be deemed obtained by Contractor for and on behalf of City.
 - (5) Any information submitted by Contractor prior to the award of Contract, or thereafter, upon request, whether or not submitted under a continuing obligation by the terms of the Contract to do so, is true and correct at the time such information is submitted or made available to the City;
 - (6) Contractor has not colluded, conspired, or agreed, directly or indirectly, with any person in regard to the terms and conditions of Contractor's Bid, except as may be permitted by the Notice to Contractors;
 - (7) Contractor has the power and the authority to enter into this Contract with City, that the individual executing this Contract is duly authorized to do so by appropriate resolution, and that this Contract shall be executed, delivered and performed pursuant to the power and authority conferred upon the person or persons authorized to bind Contractor;
 - (8) Contractor has not made an attempt to exert undue influence with the Project Manager or any other person who has directly contributed to City's decision to award the Contract to Contractor;
 - (9) There are no unresolved claims or disputes between Contractor and City which would materially affect Contractor's ability to perform under the Contract;

SECTION 00500

WELL 7 PUMP HOUSE IMPROVEMENTS, CIP PW 23-05
CUPCCAA INFORMAL BID SOLICITATION

SAMPLE CONTRACT

- (10) Contractor has furnished and will furnish true and accurate statements, records, reports, resolutions, certifications, and other written information as may be requested of Contractor by City from time to time during the term of this Contract;
 - (11) Contractor and any person performing labor and services under this Project is duly licensed as a contractor with the State of California as required by California Business & Professional Code Section 7028, as amended; and
 - (12) Contractor has fully examined and inspected the Project site and has full knowledge of the physical conditions of the Project site.
12. Assignment. This Contract and the performance required hereunder is personal to Contractor, and it shall not be assigned by Contractor. Any attempted assignment shall be null and void.
 13. Claims of Contractor. All claims pertaining to extra work, additional charges, or delays within the Contract Time or other disputes arising out of the Contract shall be submitted by Contractor in accordance with the General Conditions.
 14. Audits by City. During the term of this Contract and for a period of not less than three (3) years after the expiration or earlier termination of this Contract, City shall have the right to audit Contractor's Project-related and Work-related writings and business records, as such terms are defined in California Evidence Code Sections 250 and 1271, as amended, during the regular business hours of Contractor, or, if Contractor has no such hours, during the regular business hours of City.
 15. Notices. All contracts, agreements, appointments, approvals, authorizations, claims, demands, Change Orders, consents, designations, notices, offers, requests and statements given by either party to the other shall be in writing and shall be sufficiently given and served upon the other party if (1) personally served, (2) sent by the United States mail, postage prepaid, (3) sent by private express delivery service, or (4) in the case of a facsimile transmission, if sent to the telephone FAX number set forth below during regular business hours of the receiving party and followed with two (2) days by delivery of a hard copy of the material sent by facsimile transmission, in accordance with (1), (2) or (3) above. Personal service shall include, without limitation, service by delivery and service by facsimile transmission.

To City: City of Lathrop
City Clerk
390 Towne Centre Drive
Lathrop, CA 95330

SECTION 00500

Copy to: City of Lathrop
Department of Public Works
390 Towne Centre Drive
Lathrop, CA 95330

(209) 941-7430
FAX: (209) 941-7449
ATTN: Senior Construction Manager

To Contractor: _____

Phone: _____

Fax: _____

ATTN: _____

16. Miscellaneous

- (1) Bailee Disclaimer. The parties understand and agree that City does not purport to be Contractor's bailee, and City is, therefore, not responsible for any damage to the personal property of Contractor.
- (2) Consent. Whenever in this Contract the approval or consent of a party is required, such approval or consent shall be in writing and shall be executed by a person having the express authority to grant such approval or consent.
- (3) Controlling Law. The parties agree that this Contract shall be governed and construed by and in accordance with the Laws of the State of California.
- (4) Definitions. The definitions and terms are as defined in these specifications.
- (5) Force Majeure. Neither party shall be deemed to be in default on account of any delay or failure to perform its obligations under this Contract, which directly results from an Act of God or an act of a superior governmental authority.
- (6) Headings. The paragraph headings are not a part of this Contract and shall have no effect upon the construction or interpretation of any part of this Contract.
- (7) Incorporation of Documents. All documents constituting the Construction Documents described in Section 3 hereof and all documents which may, from time to time, be referred to in any duly executed amendment hereto are by such reference incorporated in this Contract and shall be deemed to be part of this Contract.
- (8) Integration. This Contract and any amendments hereto between the parties constitute the entire contract between the parties concerning the Project and Work, and there are no other prior oral or written contracts between the parties that are not incorporated in this Contract.

SECTION 00500

- (9) Modification of Contract. This Contract shall not be modified or be binding upon the parties unless such modification is agreed to in writing and signed by the parties.
- (10) Provision. Any contract, covenant, condition, clause, qualification, restriction, reservation, term or other stipulation in the Contract shall define or otherwise control, establish, or limit the performance required or permitted or to be required of or permitted by either party. All provisions, whether covenants or conditions, shall be deemed to be both covenants and conditions.
- (11) Resolution. Contractor shall submit with its Bid a copy of any corporate or partnership resolution or other writing, which authorizes any director, officer or other employee or partner to act for or on behalf of Contractor or which authorizes Contractor to enter into this Contract.
- (12) Severability. If a court of competent jurisdiction finds or rules that any provision of this Contract is void or unenforceable, the provisions of this Contract not so affected shall remain in full force and effect.
- (13) Status of Contractor. In the exercise of rights and obligations under this Contract, Contractor acts as an independent contractor and not as an agent or employee of City. Contractor shall not be entitled to any rights and benefits accorded or accruing to the City Council members, officers or employees of City, and Contractor expressly waives any and all claims to such rights and benefits.
- (14) Successors and Assigns. The provisions of this Contract shall inure to the benefit of, and shall apply to and bind, the successors and assigns of the parties.
- (15) Time of the Essence. Time is of the essence of this Contract and each of its provisions. In the calculation of time hereunder, the time in which an act is to be performed shall be computed by excluding the first Day and including the last. If the time in which an act is to be performed falls on a Saturday, Sunday, or any Day observed as a legal holiday by City, the time for performance shall be extended to the following Business Day.
- (16) Venue. In the event that suit is brought by either party hereunder, the parties agree that trial of such action shall be vested exclusively in the state courts of California in the County of San Joaquin or in the United States District Court for the Eastern District of California.
- (17) Recovery of costs. The prevailing party in any action brought to enforce the terms of this Contract or arising out of this Contract, including the enforcement of the indemnity provision(s), may recover its reasonable costs, including reasonable attorney's fees, incurred or expended in connection with such action against the non-prevailing party.
- (18) Contractor and subcontractors must comply with all applicable standards, orders, or requirements issued under Section 306 of the Clean Air Act (42 USC 1857(h)), Section 508 of the Clean Water Act (33 USC1368), Executive Order 11738, and Environmental Protection Agency Regulations at 40 CFR Part 15.

SECTION 00500

- (19) Contractors and subcontractors must comply with mandatory standards and policies relating to the energy efficiency which are contained in the State Energy Conservation Plan issued in compliance with the Energy Policy and Conservation ACT (Public Law 94-163, 89 stat 871).
- (20) The Contractor shall provide access to the site for the Environmental Protection Agency and its duly authorized representatives, and the City.
- (21) If during the course of construction evidence of deposit of historical or archaeological interest is found, the Contractor shall cease operation affecting the find and shall notify the City, who shall notify the EPA and the State Historic Preservation Officer. No further disturbance of the deposits shall ensue until the Contractor has been notified by the City that construction may proceed. The City will issue a notice to proceed only after the state official has surveyed the find and made a determination to the EPA and the City. Compensation to the contractor, if any, for lost time or changes in construction to avoid the find, shall be determined in accordance with changed conditions or change order provisions of the Construction Documents.
- (22) Notice to Proceed. Prior to commencing work under this Contract, CONTRACTOR shall receive a written "Notice to Proceed" from CITY. A Notice to Proceed shall not be issued until all necessary bonds and insurances have been received. City shall not be obligated to pay CONTRACTOR for any services prior to issuance of the Notice to proceed.
- (23) Signatures. The individuals executing this Contract represent and warrant that they have the right, power, legal capacity, and authority to enter into and to execute this Contract on behalf of the respective legal entities of the CONTRACTOR and the CITY. This Contract shall inure to the benefit of and be binding upon the parties hereto and their respective successors and assigns.
- (24) This project is a public works project: Contractor shall comply with requirements of California Labor Code § 1700 and following, and prevailing wages shall be paid for work performed on this project.
- (25) The statutory provisions for penalties for failing to comply with the State of California wage and labor laws be enforced, as well as that for failing to pay prevailing wages.

EXHIBITS:

EXHIBIT A: Contractor's Submitted Bid Packet

Certification of insurance, performance and payment bonds, and worker's compensation certification shall be furnished to the City by the Contractor after City Council's approval by resolution.

SECTION 00500

**WELL 7 PUMP HOUSE IMPROVEMENTS, CIP PW 23-05
CUPCCAA INFORMAL BID SOLICITATION**

SAMPLE CONTRACT

IN WITNESS WHEREOF, the parties have executed this Agreement on the date first above stated in Lathrop, California.

CONTRACTOR:

By: _____

Name: _____

Title: _____

**CITY OF LATHROP
APPROVED AS TO FORM:**

By: _____
Salvador Navarrete, City Attorney

RECOMMENDED FOR APPROVAL:

By: _____
Michael King, Assistant City Manager

APPROVED:

By: _____
Stephen J. Salvatore, City Manager

(END OF SECTION)

SECTION 00610

**WELL 7 PUMP HOUSE IMPROVEMENTS, CIP PW 23-05
CUPCCAA INFORMAL BID SOLICITATION**

PERFORMANCE BOND

Bond No: _____
Premium: _____
Contract No: _____

PERFORMANCE BOND

WHEREAS, the City Council of the City of Lathrop, State of California, and _____, ("Principal"), have entered into a Contract whereby principal agrees to install and complete certain designated public improvements. The Contract, dated _____, 20__, and identified as project **WELL 7 PUMP HOUSE IMPROVEMENTS, CIP PW 23-05** is hereby referred to and made a part hereof; and

WHEREAS, the principal is required under the terms of the Contract to furnish a bond for the faithful performance of the Contract.

NOW, THEREFORE, we, the principal and _____, as surety, are held and firmly bound unto the City of Lathrop ("City"), in the sum of _____ dollars (\$_____) lawful money of the United States, for the payment of which we bind ourselves, our heirs, successors, executors and administrators, jointly and severally.

The condition of this obligation is such that if the above principal, his or its heirs, executors, administrators, successors or assigns, shall in all things stand to and abide by, and well and truly keep and perform the covenants, conditions and provisions in the Contract and any alteration thereof made as therein provided, on his or their part, to be kept and performed at the time and in the manner therein specified, and in all respects according to their true intent and meaning, and shall indemnify and save harmless City its officers, agents and employees, as therein stipulated, then this obligation shall become null and void; otherwise it shall be and remain in full force and effect.

As part of the obligation secured hereby and in addition to the face amount specified therefor, there shall be included costs and reasonable expenses and fees, including reasonable attorney's fees, incurred by City in successfully enforcing such obligation, all to be taxed as costs and included in any judgment rendered.

The surety hereby stipulates and agrees that no change, extension of time, alteration or addition to the terms of the Contract or to the work to be performed thereunder or the specifications accompanying the same shall in any way affect its obligations on this bond, and it does hereby waive notice of any such change, extension of time, alteration or addition to the terms of the Contract or to the work or to the specifications.

SECTION 00610

WELL 7 PUMP HOUSE IMPROVEMENTS, CIP PW 23-05
CUPCAA INFORMAL BID SOLICITATION

PERFORMANCE BOND

IN WITNESS WHEREOF, this instrument has been duly executed by the Principal and

Surety above named, on _____, 20__.

ADDRESS OF Contractor:

_____	_____
_____	_____
_____	_____

ADDRESS OF SURETY:

_____	_____
_____	_____

(END OF SECTION)

SECTION 00620

**WELL 7 PUMP HOUSE IMPROVEMENTS, CIP PW 23-05
CUPCCAA INFORMAL BID SOLICITATION**

PAYMENT (LABOR AND MATERIALS) BOND

Bond No: _____
Premium: _____
Contract No. _____

PAYMENT (LABOR AND MATERIALS) BOND

WHEREAS, the City Council of the City of Lathrop, State of California, and _____, ("Principal"), have entered into an Contract whereby principal agrees to install and complete certain designated public improvements. The Contract, dated _____, 20__, and identified as project **WELL 7 PUMP HOUSE IMPROVEMENTS, CIP PW 23-05** is hereby referred to and made a part hereof; and

WHEREAS, under the terms of the Contract, principal is required before entering upon the performance of the work to file a good and sufficient payment with the City of Lathrop to secure the claims to which reference is made in Title 15 (commencing with Section 3082) of Part 4 of Division 3 of the Civil Code of the State of California.

NOW, THEREFORE, the principal and the undersigned as corporate surety, are held firmly bound unto the City of Lathrop and all Contractors, subcontractors, laborers, material, men and other persons employed in the performance of the Contract and referred to in the above-mentioned Code of Civil Procedure in the sum of _____ dollars (\$ _____), for materials furnished or labor thereon of any kind, or for amounts due under the Unemployment Insurance Act with respect to such work or labor, that the surety will pay the same in an amount not exceeding the amount set forth above, and also in case suit is brought upon this bond, will pay, in addition to the face amount thereof, costs and reasonable expenses and fees, including reasonable attorney's fees, incurred by City in successfully enforcing such obligation, to be awarded and fixed by the court, and to be taxed as costs and to be included in the judgment rendered.

It is hereby expressly stipulated and agreed that this bond shall insure to the benefit of any and all persons, companies and corporations entitled to file claims under Title 15 (commencing with Section 3082) of Part 4 of Division 3 of the Civil Code, so as to give a right of action to them or their assigns in any suit brought upon this bond.

Should the conditions of this bond be fully performed, then this obligation shall become null and void, otherwise it shall be and remain in full force and effect.

The surety hereby stipulates and agrees that no change, extension of time, alternation or addition to the terms of said Contract or the specifications accompanying the same shall in any manner affect its obligations on this bond, and it does hereby waive notice of any such change, extension, alteration or addition.

SECTION 00620

**WELL 7 PUMP HOUSE IMPROVEMENTS, CIP PW 23-05
CUPCAA INFORMAL BID SOLICITATION**

PAYMENT (LABOR AND MATERIALS) BOND

IN WITNESS WHEREOF, this instrument has been duly executed by the Principal and Surety above named, on _____, 20__.

ADDRESS OF PRINCIPAL:

_____	_____
_____	_____

ADDRESS OF SURETY:

_____	_____
_____	_____

(END OF SECTION)

SECTION 00660

WELL 7 PUMP HOUSE IMPROVEMENTS, CIP PW 23-05
CUPCAA INFORMAL BID SOLICITATION

WORKER'S COMPENSATION CERTIFICATION

WORKER'S COMPENSATION CERTIFICATION

(AS REQUIRED BY SECTION 1861 OF THE CALIFORNIA LABOR CODE)

I am aware of the provision of Section 3700 of the Labor Code which require every employer to be insured against liability for worker's compensation or to undertake self-insurance in accordance with the provisions of that code, and I will comply with such provisions before commencing the performance of the work of the Contract.

Contractor: _____

By: _____

Title: _____

(END OF SECTION)

SECTION 00670

GUARANTY (WARRANTY) BOND ACKNOWLEDGMENT

TO the City of Lathrop

The undersigned guarantees the construction and installation of the work included in this project.

A Guaranty (Warranty) Bond similar to the provided Guaranty Bond Form on the following page is required to be submitted prior to project acceptance by the City. The Guaranty (Warranty) Bond shall be ten percent (10%) of the final contract amount. The Bond will be effective for one (1) year, beginning with the date of project acceptance.

If any of the work is defective, due to faulty workmanship, materials furnished or methods of installation, or if the work or any part of it fails to operate properly as originally intended and in accordance with the Plans and Specifications, due to any of the above causes, all within one year after the date on which this contract is accepted by the City after relief from maintenance, the undersigned agrees to reimburse the City, upon demand, for its expenses incurred in restoring the project, including the cost of any such equipment or materials replaced and the cost of removing and replacing any other work necessary to make such replacement or repairs, or, upon demand by the City, to replace any such material and to repair the work completely without cost to the City so that the work will function successfully as originally contemplated.

The City shall have the unqualified option to make any needed replacements or repairs done by the undersigned. If the City elects to have the work performed by the undersigned, the undersigned agrees that the repairs shall be made and such materials as are necessary shall be furnished and installed within a reasonable time after the receipt of demand from the City. If the undersigned fails or refuses to comply with his obligations under this guaranty, the City shall be entitled to all costs and expenses, including attorney's fees.

Signature of Bidder

Date

SECTION 00670

WELL 7 PUMP HOUSE IMPROVEMENTS, CIP PW 23-05
CUPCCAA INFORMAL BID SOLICITATION

GUARANTY

Bond No: _____
Premium: _____
Contract No: _____

GUARANTY (WARRANTY) BOND

KNOW ALL PERSONS BY THESE PRESENTS, that

WHEREAS, the CITY OF LATHROP, (hereinafter referred to as "City") and _____, (hereinafter referred to as "Principal") have entered into an Agreement ("Contract") for the **WELL 7 PUMP HOUSE IMPROVEMENTS, CIP PW 23-05**; and

WHEREAS, Principal is required under the terms of the Agreement to furnish warranty security for the work performed pursuant to the Agreement in the amount of [\$ _____] to guarantee replacement and repair of the improvements as described in the Agreement for a period of one year following the date of recordation of the notice of acceptance of the Improvements against any defective work or labor done, or defective materials furnished.

NOW, THEREFORE, we, the Principal, and _____ as Surety, are held and firmly bound unto the City in the penal sum of _____ Dollars (\$ _____) lawful money of the United States, being not less than 10 percent (10%) of the amount payable by the terms of the Contract, for the payment of which sum well and truly to be made we bind ourselves, our heirs, executors, administrators and successors, jointly and severally, firmly by these presents.

The condition of this obligation is such that if Principal shall indemnify City for all loss that City may sustain by reason of any defective materials or workmanship which become apparent during the period of one year from and after acceptance of the improvements by the City Council of City, then this obligation shall be null and void; otherwise, this obligation shall remain in full force and effect.

As a part of the obligation secured hereby and in addition to the face amount specified, costs and reasonable expenses and fees shall be included, including reasonable attorneys' fees incurred by City in successfully enforcing the obligation, all to be taxed as costs and included in any judgment rendered.

Surety's obligations hereunder are independent of the obligations of any other surety for the performance of the Contract, and suit may be brought against Surety and such other sureties, jointly and severally, or against any one or more of them, or against less than all of them without impairing the City's rights against the others.

SECTION 00670

WELL 7 PUMP HOUSE IMPROVEMENTS, CIP PW 23-05
CUPCAA INFORMAL BID SOLICITATION

GUARANTY

No right of action shall accrue on this bond to or for the use of any person or corporation other than the City or its successors or assigns.

Surety shall provide City with thirty (30) days' written notice of Principal's default prior to Surety terminating, suspending or revoking the bond.

The Surety hereby stipulates and agrees that no change, extension of time, alteration or addition to the terms of the Contract or to the work to be performed thereunder or the Specifications accompanying the same shall in any way affect its obligation on this bond, and it does hereby waive any such change, extension of time, alteration or addition to the terms of the Contract or to the work or to the Specifications.

IN WITNESS WHEREOF, the above-bound parties have executed this instrument under their seals this _____ day of _____, 20_, the name and corporate seal of each corporate body being hereto affixed and these presents duly signed by its undersigned representative, pursuant to authority of its governing body.

(Principal)

By _____
Signature

Print Name and Title

*Note:
To be signed by Principal
and Surety and acknowledgment
and notarial seal attached.*

(Surety)

Address

By _____
Signature

Print Name and Title

(END OF SECTION)

SECTION 00700

GENERAL CONDITIONS

ARTICLE 1 -- DEFINITIONS

Wherever used in these General Conditions, Special Conditions, General Requirements, Technical Specifications, Construction Documents or in any other part of these specifications the following terms have the meanings indicated:

Addenda - Written or graphic instruments issued prior to the opening of Bids, which make additions, deletions, or revisions to the Construction Documents.

Application for Payment - The form furnished by the CITY which is to be used by the CONTRACTOR to request progress or final payment and which includes such supporting documentation as is required by the Construction Documents.

Bid - The offer or proposal of the Bidder submitted on the prescribed form setting forth the price or prices for the WORK.

Bonds - Bid, Performance, and Payment Bonds and other instruments, which protect against loss due to inability or refusal of the CONTRACTOR to perform its Contract.

Change Order - A document recommended by the ENGINEER, which is signed by the CONTRACTOR and the CITY and authorizes an addition, deletion, or revision in the WORK, or an adjustment in the Contract Price or the Contract Time, issued on or after the Effective Date of the Contract.

CITY - The public body or authority, corporation, association, firm, or person with whom the CONTRACTOR has entered into the Contract and for whom the WORK is to be provided. Said public body is The City of Lathrop, located at 390 Towne Centre Drive, Lathrop, California 95330.

CITY'S REPRESENTATIVE - Contract construction manager or City personnel at the City's discretion.

City Engineer - The City Engineer is the City Engineer of the City of Lathrop.

Construction Documents - The Notice to Contractors, Instructions to Bidders, Bid Forms (including the Bid, Bid Schedule(s), Information Required of Bidder, Bid Bond, and all required certificates and affidavits), Contract, Performance Bond, Payment Bond, General Conditions, Supplementary Conditions, Technical Specifications, Drawings, and all addenda, and change orders executed pursuant to the provisions of the Construction Documents.

Contract - The written contract between the CITY and the CONTRACTOR covering the WORK to be performed; when other documents are attached to the Contract they become part of the contract.

SECTION 00700

WELL 7 PUMP HOUSE IMPROVEMENTS, CIP PW 23-05
CUPCCAA INFORMAL BID SOLICITATION

GENERAL CONDITIONS

Contract Price - The total monies payable by the CITY to the CONTRACTOR under the terms and conditions of the Construction Documents.

Contract Time - The number of successive calendar days stated in the Construction Documents for the completion of the WORK.

CONTRACTOR - The person, firm, or corporation with whom the CITY has executed the Contract.

COST OF WORK – The sum of all costs necessarily incurred and paid by the CONTRACTOR for labor, materials, and equipment in the proper performance of extra work.

Day - A calendar day of 24 hours measured from midnight to the next midnight.

Defective Work - Work that is unsatisfactory, faulty, or deficient; or that does not conform to the Construction Documents or the State Standard Specifications; or that does not meet the requirements of any inspection, reference standard, test, or approval referred to in the Construction Documents; or work that has been damaged prior to the ENGINEER'S recommendation of final payment.

Drawings - The drawings, plans, maps, profiles, diagrams, and other graphic representations which show the character, location, nature, extent, and scope of the WORK and which have been prepared by the ENGINEER and are referred to in the Construction Documents. Shop Drawings are not Drawings as so defined.

Effective Date of the Contract - The date indicated in the Contract on which it was executed, but if no such date is indicated it means the date on which the Contract is signed and delivered by the last of the two parties to sign and deliver.

ENGINEER – The person, firm, or corporation responsible for plan preparation and named as such in the Construction Documents.

Field Order - A written order issued by the City, which may or may not involve a change in the WORK.

Inspector – The person, firm, or corporation, as designated by the CITY as responsible for determining whether or not the WORK is constructed in accordance with the Construction Documents.

Laws and Regulations; Laws or Regulations - Laws, rules, regulations, ordinances, codes, and/or orders promulgated by a lawfully constituted body authorized to issue such Laws and Regulations.

Notice of Award - The written notice by the CITY to the apparent successful bidder stating that upon compliance by the apparent successful bidder with the conditions precedent enumerated therein within the time specified, the CITY would enter into a Contract.

SECTION 00700

WELL 7 PUMP HOUSE IMPROVEMENTS, CIP PW 23-05
CUPCCAA INFORMAL BID SOLICITATION

GENERAL CONDITIONS

Notice to Proceed - The written notice issued by the CITY to the CONTRACTOR authorizing the CONTRACTOR to proceed with the WORK and establishing the date of commencement of the Contract Time.

Owner – The Owner is the City of Lathrop located at 390 Towne Centre Drive, Lathrop, California 95330.

Partial Completion - Placing a portion of the WORK in service for the purpose for which it is intended (or a related purpose) before reaching Substantial Completion of the WORK.

Project - The total construction of which the WORK to be provided under the Construction Documents, may be the whole, or a part thereof.

Project Engineer – Who is the ENGINEER’S Agent, will act as directed by and under the supervision of the ENGINEER and will confer with the ENGINEER regarding its actions.

Project Manager - The authorized representative of the City who is assigned to manage the Project.

Shop Drawings - All drawings, diagrams, illustrations, schedules and other data which are specifically prepared by or for the CONTRACTOR and submitted by the CONTRACTOR to illustrate some portion of WORK and all illustrations, brochures, standard schedules, performance charts, instructions, and diagrams to illustrate material or equipment for some portion of the WORK.

Standard Plans - The latest edition of the Standard Plans of the State of California, Department of Transportation. Any reference therein to the State of California or a State agency, office or officer shall be interpreted to refer to the City of Lathrop or its corresponding agency, office or officer acting under this contract.

Standard Specifications - The latest edition of the Standard Specifications of the State of California, Department of Transportation. Any reference therein to the State of California or a State agency, office or officer shall be interpreted to refer to the City of Lathrop or its corresponding agency, office or officer acting under this contract. Only those specific sections of the Standard Specifications that are referenced shall be incorporated into the Construction Documents.

Subcontractor - An individual, firm, or corporation having a direct contract with the CONTRACTOR or with any other Subcontractor for the performance of a part of the WORK at the site.

Substantial Completion - Refers to when the WORK has progressed to the point where, in the opinion of the ENGINEER as evidenced by the Certificate of Substantial Completion/Notice of Completion as applicable, it is sufficiently complete, in accordance with the Construction Documents, so that the WORK can be utilized for the purposes for which it is intended; or if there be no such certificate issued, when final payment is due in accordance with Paragraph 14.8. The terms "substantially complete" and "substantially completed" as applied to any work refers to substantial completion thereof.

SECTION 00700

WELL 7 PUMP HOUSE IMPROVEMENTS, CIP PW 23-05
CUPCCAA INFORMAL BID SOLICITATION

GENERAL CONDITIONS

Supplementary Conditions - The part of the Construction Documents, which make additions, deletions, or revisions to these General Conditions.

Supplier - A manufacturer, fabricator, supplier, distributor, material man, or vendor.

Technical Specifications - Those portions of the Construction Documents consisting of the General Requirements and Technical Requirements.

Underground Utilities - All pipelines, conduits, ducts, cables, wires, manholes, vaults, tanks, tunnels, or other such facilities or attachments, and any encasements containing such facilities which have been installed underground to furnish any of the following services or materials: water, sewage and drainage removal, electricity, gases, steam, liquid petroleum products, telephone or other communications, cable television, traffic, or other control systems.

WORK - The entire completed construction required to be furnished under the Construction Documents. WORK is the result of performing services, furnishing labor and furnishing and incorporating materials and equipment into the construction, all as required by the Construction Documents.

ARTICLE 2 -- PRELIMINARY MATTERS

2.1 Delivery of Bonds/Insurance Certificates

- A. When the CONTRACTOR delivers the signed Contracts to the CITY, the CONTRACTOR shall also deliver to the CITY such Bonds and Insurance Policies and Certificates as the CONTRACTOR may be required to furnish in accordance with the Construction Documents.

2.2 Copies of Documents

- A. The CITY will send two (2) copies of the Contract to the Contractor for signature. After signing and returning both copies, the CITY shall furnish to the Contractor one (1) original copy of the executed Contract.

2.3 Commencement of Contract Time; Notice to Proceed

- A. The Contract Time will start to run on the commencement date stated in the Notice to Proceed.

2.4 Starting the Project

- A. The CONTRACTOR shall begin to perform the WORK within 10 working days after the commencement date stated in the Notice to Proceed, but no work shall be done at the site prior to said commencement date.
- B. Before undertaking each part of the WORK, the CONTRACTOR shall carefully study and compare the Construction Documents and check and verify pertinent figures shown thereon and all applicable field measurements. The CONTRACTOR shall promptly

SECTION 00700

report in writing to the CITY any conflict, error, or discrepancy which the CONTRACTOR may discover and shall obtain a written interpretation or clarification from the CITY/ENGINEER before proceeding with any work affected thereby.

- C. The CONTRACTOR shall submit to the CITY for review by the CITY/ ENGINEER those documents called for under Section entitled "Contractor Submittals" in the General Requirements.

2.5 Subcontract Limitations

- A. The CONTRACTOR shall perform not less than 50 percent of the Work with its own forces (i.e., without subcontracting). The 50 percent requirement shall be understood to refer to the Work, the value of which totals not less than 50 percent of the Contract Price.

2.6 Pre-Construction Conference

- A. A pre-construction conference attended by the CONTRACTOR, the CITY and others as appropriate will be held to discuss the WORK in accordance with the applicable procedures specified in the General Requirements. The CONTRACTOR shall submit the Project Schedule at this meeting.

2.7 Finalizing Schedules

- A. At least 7 days before submittal of the first Application for Payment a conference attended by the CONTRACTOR, the CITY, and others as appropriate will be held to finalize the schedules submitted in accordance with the General Requirements.

2.8 Hours of Work

- A. The CONTRACTOR shall schedule an 8-hour workday between the hours of 7:00 a.m. and 6:00 p.m. on Monday through Friday unless otherwise approved by the CITY or modified in the Supplementary Conditions. No work requiring City inspection shall be allowed outside of normal working hours, or on weekends or holidays without written authorization of the CITY. Normal working hours are defined as being Monday through Friday, 8:00 a.m. to 5:00 p.m.

2.9 City Furnished Materials

- A. The CITY will not furnish any materials for this project. All materials required for the successful performance of this contract shall be furnished by the Contractor.

ARTICLE 3 -- CONSTRUCTION DOCUMENTS: INTENT, AMENDING, REUSE

3.1 Intent

- A. The Construction Documents comprise the entire contract between the CITY and the CONTRACTOR concerning the WORK. The Construction Documents are

SECTION 00700

complementary; what is called for by one is as binding as if called for by all. The Construction Documents will be construed in accordance with the law of the place of the State of California and local municipal codes and regulations.

- B. It is the intent of the Construction Documents to describe the WORK, functionally complete, to be constructed in accordance with the Construction Documents. Any work, materials, or equipment that may reasonably be inferred from the Construction Documents as being required to produce the intended result shall be supplied whether or not specifically called for. When words which have a well-known technical or trade meaning are used to describe work, materials, or equipment such words shall be interpreted in accordance with that meaning. Reference to standard specifications, manuals, or codes of any technical society, organization, or association, or to the Laws or Regulations of any governmental authority, whether such reference be specific or by implication, shall mean the latest standard specification, manual, code, or Laws or Regulations in effect at the time of opening of Bids, except as may be otherwise specifically stated. However, no provision of any referenced standard specification, manual, or code (whether or not specifically incorporated by reference in the Construction Documents) shall be effective to change the duties and responsibilities of the CITY, the CONTRACTOR, or the ENGINEER or any of their consultants, agents, or employees from those set forth in the Construction Documents.
- C. If, during the performance of the WORK, the CONTRACTOR finds a conflict, error, or discrepancy in the Construction Documents, the CONTRACTOR shall so report to the CITY in writing at once, and before proceeding with the work affected thereby, shall obtain a written interpretation, clarification, or correction from the ENGINEER.

3.2 Order of Precedence of Construction Documents

- A. In resolving conflicts resulting from conflicts, errors, or discrepancies in any of the Construction Documents, the order of precedence shall be as follows:
 - 1. Change orders
 - 2. Contract
 - 3. Addenda
 - 4. CONTRACTOR'S Bid (Bid Form)
 - 5. Supplementary Conditions
 - 6. Notice Inviting Bids
 - 7. Instructions to Bidders
 - 8. General Conditions
 - 9. Technical Specifications
 - 10. Referenced Standard Specifications
 - 10a. Caltrans Standard Specifications
 - 10b. Lathrop Design & Construction Standards
 - 11. Drawings
- B. With reference to the Drawings the order of precedence is as follows:

SECTION 00700

1. Figures govern over scaled dimensions
2. Detail drawings govern over general drawings
3. Addenda/change order drawings govern over Contract Drawings
4. Contract Drawings govern over standard drawings

3.3 Amending and Supplementing Construction Documents

- A. The Construction Documents may be amended to provide for additions, deletions, and revisions in the WORK or to modify the terms and conditions thereof by a Change Order (pursuant to Article 10).

3.4 Reuse of Documents

- A. Neither the CONTRACTOR, nor any Subcontractor or Supplier, nor any other person or organization performing any of the WORK under a contract with the CITY shall have or acquire any title to ownership rights in any of the Drawings, Technical Specifications, or other documents used on the WORK, and they shall not reuse any of them on the extensions of the Project or any other project without written consent.

3.5 Conflicts within Construction Documents

- A. Should the Construction Documents contain conflicts and/or contradictions, the more stringent shall apply at the CITY's discretion.

ARTICLE 4 -- AVAILABILITY OF LANDS; PHYSICAL CONDITIONS; REFERENCE POINTS

4.1 Availability of Lands

- A. The CITY shall furnish, as indicated in the Construction Documents, the lands upon which the WORK is to be performed, rights-of-way and easements for access thereto, and such other lands which are designated for the use of the CONTRACTOR. Easements for permanent structures or permanent changes in existing facilities will be obtained and paid for by the CITY, unless otherwise provided in the Construction Documents. Nothing contained in the Construction Documents shall be interpreted as giving the CONTRACTOR exclusive occupancy of the lands or rights-of-way provided. The CONTRACTOR shall provide for all additional lands and access thereto that may be required for temporary construction facilities or storage of materials and equipment; provided, that the CONTRACTOR shall not enter upon nor use any property not under the control of the CITY until a written temporary construction easement agreement has been executed by the CONTRACTOR and the property owner, and a copy of said easement furnished to the CITY'S REPRESENTATIVE prior to said use; and, neither the CITY nor the ENGINEER shall be liable for any claims or damages resulting from the CONTRACTOR'S unauthorized trespass or use of any such properties.

SECTION 00700

4.2 Physical Conditions - Subsurface and Existing Structures

- A. Explorations and Reports: Reference is made to the Paragraph entitled "Physical Conditions" of the Supplementary Conditions for identification of those reports of explorations and tests of sub- surface conditions at the site that have been utilized by the ENGINEER in the preparation of the Construction Documents. The CONTRACTOR may rely upon the accuracy of the technical data contained in such reports, however, the interpretation of such technical data, including any interpolation or extrapolation thereof, together with non-technical data, interpretations, and opinions contained in such reports or the completeness thereof is the responsibility of the CONTRACTOR.
- B. Existing Structures: Reference is made to the Paragraph entitled "Physical Conditions" of the Supplementary Conditions for identification of those drawings of physical conditions in or relating to existing surface and subsurface structures (except Underground Utilities referred to in Paragraph 4.4 herein) which are at or contiguous to the site that have been utilized by the ENGINEER in the preparation of the Construction Documents. The CONTRACTOR may rely upon the accuracy of the technical data contained in such drawings, however, the interpretation of such technical data, including any interpolation or extrapolation thereof, together with non-technical data, interpretations, and opinions contained in such drawings or the completeness thereof is the responsibility of the CONTRACTOR.

4.3 Differing Site Conditions

- A. The CONTRACTOR shall notify the CITY'S REPRESENTATIVE in writing of the following unforeseen conditions, hereinafter called differing site conditions, promptly upon their discovery (but in no event later than 14 days from the discovery) and before they are disturbed:
 - 1. Subsurface or latent physical conditions at the site of the WORK differing materially from those indicated, described, or delineated in the Construction Documents including those reports and documents discussed in Paragraph 4.2; and.
 - 2. Unknown physical conditions at the site of the WORK of an unusual nature differing materially from those ordinarily encountered and generally recognized as inherent in work of the character provided for in the Construction Documents including those reports and documents discussed in Paragraph 4.3.
- B. The CITY'S REPRESENTATIVE will review the pertinent conditions and determine the necessity of obtaining additional explorations or tests with respect thereto.
- C. If the CITY'S REPRESENTATIVE concludes that because of newly discovered conditions a change in the Construction Documents is required, a Change Order will be issued as provided in Article 10 to reflect and document the consequences of the difference.

SECTION 00700

WELL 7 PUMP HOUSE IMPROVEMENTS, CIP PW 23-05
CUPCCAA INFORMAL BID SOLICITATION

GENERAL CONDITIONS

- D. In each such case, an increase or decrease in the Contract Price or an extension or shortening of the Contract Time, or any combination thereof, will be allowable to the extent that they are attributable to any such difference. If the CITY and the CONTRACTOR are unable to agree as to the amount or length thereof, a claim may be made therefore as provided in Articles 11 and 12.
- E. The CONTRACTOR'S failure to give notice of differing site conditions within 14 days of their discovery or before they are disturbed shall constitute a waiver of all claims in connection therewith, whether direct or consequential in nature.

4.4 Physical Conditions – Underground Utilities

- A. Shown or Indicated: The information and data shown or indicated in the Construction Documents with respect to existing Underground Utilities at or contiguous to the site are based on information and data furnished to the ENGINEER by the CITY, Underground Utility Companies or by others. Unless it is expressly provided in the Supplementary Conditions and/or the Section entitled "Protection and Restoration of Existing Facilities" of the General Requirements, the CITY and the ENGINEER shall not be responsible for the accuracy or completeness of any such information or data, and the CONTRACTOR shall have full responsibility for reviewing and checking all such information and data, for locating all Underground Utilities shown or indicated in the Construction Documents, for coordination of the WORK with Underground Utility Companies during construction, for the safety and protection thereof and repairing any damage thereto resulting from the WORK, the cost of which will be considered as having been included in the Contract Price.
- B. Not Shown or Indicated: If an Underground Utility is uncovered or revealed at or contiguous to the site which was not shown or indicated in the Construction Documents and which the CONTRACTOR could not reasonably have been expected to be aware of, the CONTRACTOR shall identify to the CITY'S REPRESENTATIVE of such Underground Utility and give written notice thereof in accordance with the requirements of the Supplementary Conditions and Section entitled "Protection and Restoration of Existing Facilities" of the General Requirements.

4.5 Reference Points

- A. The ENGINEER will provide the CONTRACTOR with drawings showing benchmarks and reference points as it deems necessary to establish lines and grades required for the completion of the Site Work specified in the Contract Documents. The CONTRACTOR shall make or furnish all surveys and set all construction stakes necessary for the completion of the work.
- B. The CONTRACTOR shall preserve all bench marks, stakes, and other survey marks, and in case of their removal or destruction by its own employees or by its subcontractor's employees, the CONTRACTOR shall be responsible for the accurate replacement of such reference points by professionally qualified personnel.

SECTION 00700

4.6 Asbestos, Hazardous Waste, or Toxic or Radioactive Materials

- A. If the CONTRACTOR observes, uncovers, or otherwise becomes aware of any asbestos, hazardous waste, or toxic or radioactive material at the site to which the CONTRACTOR or any Subcontractor, Supplier, or other person may be exposed, the CONTRACTOR shall immediately notify the CITY'S REPRESENTATIVE and thereafter confirm any oral notice in writing. The CITY'S REPRESENTATIVE shall promptly consult with the ENGINEER and the CONTRACTOR concerning such condition and determine the necessity of CITY'S retaining special consultants or qualified experts to deal therewith. The CONTRACTOR shall not perform any work in connection therewith prior to receipt of special written instructions from the CITY'S REPRESENTATIVE.

ARTICLE 5 -- BONDS AND INSURANCE

5.1 Performance and Other Bonds

- A. The CONTRACTOR shall furnish satisfactory Performance Bond in the amount of 100 percent of the Contract Price and Payment Bond in the amount of 100 percent of the Contract Price as security for the faithful performance and payment of all the CONTRACTOR'S obligations under the Construction Documents. The Guaranty (Warranty) Bond shall remain in effect at least until one year after the date of Acceptance of Public Improvements by the City as applicable, except as otherwise provided by Law or Regulation or by the Construction Documents. The CONTRACTOR shall also furnish such other Bonds as may be required by the Supplementary Conditions.
- B. If the surety on any Bond furnished by the CONTRACTOR is declared a bankrupt or becomes insolvent or its right to do business is terminated in any state where any part of the WORK is located, the CONTRACTOR shall within 7 days thereafter substitute another Bond and Surety, which must be acceptable to the CITY.

5.2 Insurance

- A. Category 2 "Intermediate Risk"

Insurance Requirements

- i. Commercial General Liability

a. Vendor shall maintain commercial general liability insurance with coverage at least as broad as Insurance Services Office form CG 00 01, in an amount not less than two million dollars (\$2,000,000) per occurrence for bodily injury, personal injury, and property damage, including without limitation, blanket contractual liability. If a general aggregate limit applies, either the general aggregate limit shall apply separately to this project/location or the general aggregate limit shall be twice the required occurrence limit. Vendor's general liability policies shall be primary and shall not seek contribution from the City's coverage, and be endorsed using Insurance Services Office form CG 20 10 (or equivalent) to provide that City and its officers, officials, employees, and agents shall be additional insureds under such policies. For

SECTION 00700

WELL 7 PUMP HOUSE IMPROVEMENTS, CIP PW 23-05
CUPCCAA INFORMAL BID SOLICITATION

GENERAL CONDITIONS

construction projects, an endorsement providing completed operations coverage for the additional insured, ISO form CG 20 37 (or equivalent), is also required.

b. Any failure to comply with reporting provisions of the policies by Vendor shall not affect coverage provided the City.

c. Coverage shall state that Vendor insurance shall apply separately to each insured against whom claim is made or suit is brought, except with respect to the limits of the insurer's liability.

d. Coverage shall contain a waiver of subrogation in favor of the City.

ii. Business Automobile Liability

a. Vendor shall provide auto liability coverage for owned, non-owned, and hired autos using ISO Business Auto Coverage form CA 00 01 (or equivalent) with a limit of no less than two million dollars (\$2,000,000) per accident.

iii. Workers' Compensation and Employers' Liability- Statutory

a. Vendor shall maintain Workers' Compensation Insurance and Employer's Liability Insurance with limits of at least one million dollars (\$1,000,000). Vendor shall submit to City, along with the certificate of insurance, a waiver of subrogation endorsement in favor of City, its officers, agents, employees, and volunteers.

(Coverage can be waived by city, if vendor, in writing, confirms not required to carry coverage)

iv. All Coverages

a. Each insurance policy required by the agreement shall be endorsed to state that coverage shall not be suspended, voided, cancelled, or reduced in limits except after thirty (30) days' prior written notice has been given to the City, except that ten (10) days' prior written notice shall apply in the event of cancellation for nonpayment of premium.

b. All self-insurance, self-insured retentions, and deductibles must be declared and approved by the City.

c. Evidence of Insurance - Prior to commencement of work, the Vendor shall furnish the City with certificates, additional insured endorsements, and waivers of subrogation evidencing compliance with the insurance requirements above. The Vendor must agree to provide complete, certified copies of all required insurance policies if requested by the City.

d. Acceptability of Insurers - Insurance shall be placed with insurers admitted in the State of California and with an AM Best rating of A- VII or higher.

SECTION 00700

- e. Subcontractors and Consultants - A category of risk and the applicable insurance requirements will be determined on a “per subcontractor” or “per consultant” basis, considering the particular work to be done by the subcontractor or consultant and the interrelationship of that work to other work being conducted by the Vendor.

ARTICLE 6 -- CONTRACTOR'S RESPONSIBILITIES

6.1 Supervision and Superintendence

- A. The CONTRACTOR shall supervise and direct the WORK competently and efficiently, devoting such attention thereto and applying such skills and expertise as may be necessary to perform the WORK in accordance with the Construction Documents. The CONTRACTOR shall be responsible for the means, methods, techniques, sequences, and procedures of construction and safety precautions and programs incidental thereto. The CONTRACTOR shall be responsible to see that the finished WORK complies accurately with the Construction Documents.
- B. The CONTRACTOR shall designate in writing and keep on the work site at all times during its progress a technically qualified, English-speaking superintendent, who shall not be replaced without written notice to the CITY. The superintendent will be the CONTRACTOR'S representative at the site and shall have authority to act on behalf of the CONTRACTOR. All communications given to the superintendent shall be as binding as if given to the CONTRACTOR. The CONTRACTOR shall issue all its communications to the CITY'S REPRESENTATIVE.
- C. The CONTRACTOR'S supervisor or superintendent shall be present at the site of the WORK at all times while work is in progress. Failure to observe this requirement shall be considered as suspension of the WORK by the CONTRACTOR until such time as such supervisor or superintendent is again present at the site.

6.2 Labor, Materials, and Equipment

- A. The CONTRACTOR shall provide competent, suitably qualified personnel to survey and lay out the WORK and perform construction as required by the Construction Documents. The CONTRACTOR shall furnish, erect, maintain, and remove the construction plant and any temporary works as may be required. The CONTRACTOR shall at all times maintain good discipline and order at the site. Except in connection with the safety or protection of persons or the WORK or property at the site or adjacent thereto, and except as otherwise indicated in the Construction Documents, all work at the site shall be performed during regular working hours, and the CONTRACTOR will not permit overtime work or the performance of work on Saturday, Sunday, or any legal State, Federal or CITY holiday without the written consent of the CITY'S REPRESENTATIVE.
- B. Except as otherwise provided in this Paragraph, the CONTRACTOR shall receive no additional compensation for overtime work, i.e., work in excess of 8 hours in any one calendar day or 40 hours in any one calendar week, even though such overtime work may

SECTION 00700

be required under emergency conditions and may be ordered by the CITY'S REPRESENTATIVE in writing. Additional compensation will be paid the CONTRACTOR for overtime work only in the event the CITY'S REPRESENTATIVE orders extra work and the change order specifically authorizes the use of overtime work and then only to such extent as overtime wages are regularly being paid by the CONTRACTOR for overtime work of a similar nature in the same locality.

- C. All costs of inspection and testing performed during overtime work or on Saturday, Sunday, or any legal holiday by the CONTRACTOR, which is allowed solely for the convenience of the CONTRACTOR, shall be borne by the CONTRACTOR. The CITY shall have the authority to deduct the cost of all such inspection and testing from any partial payments otherwise due to the CONTRACTOR.
- D. Unless otherwise specified in the Construction Documents, the CONTRACTOR shall furnish and assume full responsibility for all materials, equipment, labor, transportation, construction equipment and machinery, tools, appliances, fuel, power, light, heat, telephone, water, sanitary facilities, and all other facilities and incidentals necessary for the furnishing, performance, testing, start-up, and completion of the WORK.
- E. All materials and equipment to be incorporated into the WORK shall be of good quality and new, except as otherwise provided in the Construction Documents. All Suppliers' warranties and guarantees specifically called for by the Specifications shall expressly run to the benefit of the CITY. If required by the CITY'S REPRESENTATIVE, the CONTRACTOR shall furnish satisfactory evidence (including reports of required tests) as to the kind and quality of materials and equipment. All materials and equipment shall be applied, installed, connected, erected, used, cleaned, and conditioned in accordance with the instructions of the applicable Supplier except as otherwise provided in the Construction Documents; but no provisions of any such instructions will be effective to assign to the CITY, or any of the CITY's consultants, agents, or employees, any duty or authority to supervise or direct the furnishing or performance of the WORK or any duty or authority to undertake responsibility contrary to the provisions of Paragraphs 9.9C and 9.9D.

6.3 **Adjusting Progress Schedule**

- A. The CONTRACTOR shall submit any adjustments in the progress schedule to the CITY'S REPRESENTATIVE for acceptance in accordance with the provisions for "Contractor Submittals" in the General Requirements.

6.4 **Substitutes or "Or-Equal" Items**

- A. The CONTRACTOR shall submit proposed substitutes or "or-equal" items in accordance with the provisions for "Contractor Submittals" in the General Requirements.

SECTION 00700

6.5 Concerning Subcontractors, Suppliers, and Others

- A. The CONTRACTOR shall be responsible to the CITY and the ENGINEER for the acts and omissions of its subcontractors and their employees regardless of tier to the same extent as CONTRACTOR is responsible to the CITY and the ENGINEER for the acts and omissions of its own employees. Nothing contained in this Paragraph shall create any contractual relationship between any subcontractor and the CITY or the ENGINEER nor relieve the CONTRACTOR of any liability or obligation under the prime Contract.

6.6 Permits

- A. Contractor shall furnish the City a copy of a valid, current City of Lathrop Business License prior to the commencement of the work. Details may be found at <https://www.ci.lathrop.ca.us/documents>.
- B. Unless otherwise provided in the Supplementary Conditions, the CONTRACTOR shall obtain and pay for all construction permits and licenses from the agencies having jurisdiction, including the furnishing of insurance and bonds if required by such agencies. The enforcement of such requirements under this Contract shall not be made the basis for claims for additional compensation. The CITY shall assist the CONTRACTOR, when necessary, in obtaining such permits and licenses. The CONTRACTOR shall pay all governmental charges and inspection fees necessary for the prosecution of the WORK, which are applicable at the time of opening of Bids. The CONTRACTOR shall pay all utility charges for connections to the WORK.
- C. The CONTRACTOR shall pay all license fees and royalties and assume all costs incident to the use in the performance of the WORK or the incorporation in the WORK of any invention, design, process, product, or device which is the subject of patent rights or copyrights held by others. If a particular invention, design, process, product, or device is specified in the Construction Documents for use in the performance of the WORK and if to the actual knowledge of the CITY or the ENGINEER its use is subject to patent rights or copyrights calling for the payment of any license fee or royalty to others, the existence of such rights shall be disclosed by the CITY in the Construction Documents. The CONTRACTOR shall indemnify, defend and hold harmless the CITY and the ENGINEER and anyone directly or indirectly employed by either of them from and against all claims, damages, losses, and expenses (including attorneys' fees and court costs) arising out of any infringement of patent rights or copyrights incident to the use in the performance of the WORK or resulting from the incorporation in the WORK of any invention, design, process, product, or device not specified in the Construction Documents, and shall defend all such claims in connection with any alleged

6.7 Laws and Regulations

- A. The CONTRACTOR shall observe and comply with all federal, state, and local laws, ordinances, codes, orders, and regulations which in any manner affect those engaged or employed on the WORK, the materials used in the WORK, or the conduct of the WORK. If any discrepancy or inconsistency should be discovered in this Contract in

SECTION 00700

relation to any such law, ordinance, code, order, or regulation, the CONTRACTOR shall report the same in writing to the CITY'S REPRESENTATIVE. The CONTRACTOR shall indemnify, defend, and hold harmless the CITY, the ENGINEER, and their officers, agents, and employees against all claims or liability arising from violation of any such law, ordinance, code, order, or regulation, whether by CONTRACTOR or by its employees or subcontractors. Any particular law or regulation specified or referred to elsewhere in the Construction Documents shall not in any way limit the obligation of the CONTRACTOR to comply with all other provisions of federal, state, and local laws and regulations. Where an individual State acts on occupational safety and health standards has been approved by Federal authority, then the provisions of said State act shall control.

6.8 Taxes

- A. The CONTRACTOR shall pay all sales, consumer, use, and other similar taxes required to be paid by the CONTRACTOR in accordance with the Laws and Regulations of the place of the Project, which are applicable during the performance of the WORK.

6.9 Use of Premises

- A. The CONTRACTOR shall confine construction equipment, the storage of materials and equipment, and the operations of workers to (1) the Project site, (2) the land and areas identified in and permitted by the Construction Documents, and (3) the other land and areas permitted by Laws and Regulations, rights-of-way, permits, and easements. The CONTRACTOR shall assume full responsibility for any damage to any such land or area, or to the CITY or occupant thereof or of any land or areas contiguous thereto, resulting from the performance of the WORK. Should any claim be made against the CITY or the ENGINEER by any such owner or occupant because of the performance of the WORK, the CONTRACTOR shall promptly attempt to settle with such other party by contract or otherwise resolve the claim through litigation. The CONTRACTOR shall, to the fullest extent permitted by Laws and Regulations, indemnify, defend, and hold the CITY and the ENGINEER harmless from and against all claims, damages, losses, and expenses (including, but not limited to, fees of engineers, architects, attorneys, and other professionals and court costs) arising directly, indirectly, or consequentially out of any action, legal or equitable, brought by any such other party against the CITY or the ENGINEER to the extent based on a claim arising out of the CONTRACTOR'S performance of the work.

6.10 Safety and Protection

- A. The CONTRACTOR shall be responsible for initiating, maintaining, and supervising all safety precautions and programs in connection with the WORK. The CONTRACTOR shall take all necessary precautions for the safety of, and shall provide the necessary protection to prevent damage, injury or loss to:
 - 1. All employees on the WORK and other persons and organizations who may be affected thereby;

SECTION 00700

2. All the WORK and materials and equipment to be incorporated therein, whether in storage on or off the site; and
 3. Other property at the site or adjacent thereto, including trees, shrubs, lawns, walks, pavements, roadways, structures, and utilities not designated for removal, relocation, or replacement in the course of construction.
- B. The CONTRACTOR shall comply with all applicable Laws and Regulations (whether referred to herein or not) of any public body having jurisdiction for the safety of persons or property or to protect them from damage, injury, or loss and shall erect and maintain all necessary safeguards for such safety and protection. The CONTRACTOR shall notify CITY'S REPRESENTATIVE of adjacent property and utilities when prosecution of the WORK may affect them, and shall cooperate with them in the protection, removal, relocation, and replacement of their property.
- C. The CONTRACTOR shall designate a responsible representative at the site whose duty shall be the prevention of accidents. This person shall be the CONTRACTOR'S superintendent unless otherwise designated in writing by the CONTRACTOR to the CITY'S REPRESENTATIVE.

6.11 Shop Drawings and Samples

- A. After checking and verifying all field measurements and after complying with applicable procedures specified in the General Requirements, the CONTRACTOR shall submit to the CITY'S REPRESENTATIVE for review all shop drawings in accordance with the accepted schedule of Shop Drawings submittals specified in the General Requirements.
- B. The CONTRACTOR shall also submit to the CITY'S REPRESENTATIVE for review all samples in accordance with the accepted schedule of Sample submittals specified in the General Requirements.
- C. Before submittal of each shop drawing or sample, the CONTRACTOR shall have determined and verified all quantities, dimensions, specified performance criteria, installation requirements, materials, catalog numbers, and similar data with respect thereto and reviewed or coordinated each shop drawing or sample with other shop drawings and samples and with the requirements of the WORK and the Construction Documents.

6.12 Continuing the Work

- A. The CONTRACTOR shall carry on the WORK and adhere to the progress schedule during all disputes or disagreements with the CITY. No work shall be delayed or postponed pending resolution of any disputes or disagreements, except as the CONTRACTOR and the CITY may otherwise agree in writing.

SECTION 00700

6.13 Liquidated Damages

- A. See Section *00100 - Instructions to Bidders*.

6.14 Indemnification

- A. To the fullest extent permitted by Laws and Regulations, the CONTRACTOR shall indemnify, defend, and hold harmless the CITY, the ENGINEER, and their officers, directors, agents, and employees, against and from all claims and liability arising under, by reason of or incidentally to the Contract or any performance of the WORK, but not from the active negligence or willful misconduct of the CITY and/or the ENGINEER. Such indemnification by the CONTRACTOR shall include but not be limited to the following:
1. Liability or claims resulting directly or indirectly from the negligence or carelessness of the CONTRACTOR, its employees, or agents in the performance of the WORK, or in guarding or maintaining the same, or from any improper materials, implements, or appliances used in its construction, or by or on account of any act or omission of the CONTRACTOR, its employees, or agents;
 2. Liability or claims arising directly or indirectly from bodily injury, occupational sickness or disease, or death of the CONTRACTOR'S or Subcontractor's own employees engaged in the WORK resulting in actions brought by or on behalf of such employees against the CITY and/or the ENGINEER;
 3. Liability or claims arising directly or indirectly from or based on the violation of any law, ordinance, regulation, order, or decree, whether by the CONTRACTOR, its employees, or agents;
 4. Liability or claims arising directly or indirectly from the use or manufacture by the CONTRACTOR, its employees, or agents in the performance of this Contract of any copyrighted or uncopyrighted composition, secret process, patented or unpatented invention, article, or appliance, unless otherwise specifically stipulated in this Contract;
 5. Liability or claims arising directly or indirectly from the breach of any warranties, whether express or implied, made to the CITY or any other parties by the CONTRACTOR, its employees, or agents;
 6. Liabilities or claims arising directly or indirectly from the willful misconduct of the CONTRACTOR, its employees, or agents; and,
 7. Liabilities or claims arising directly or indirectly from any breach of the obligations assumed herein by the CONTRACTOR.

SECTION 00700

- B. The CONTRACTOR shall reimburse the CITY for all costs and expenses, (including but not limited to fees and charges of engineers, architects, attorneys, and other professionals and court costs) incurred by said CITY in enforcing the provisions of this Paragraph 6.13.
- C. The indemnification obligation under this Paragraph 6.13 shall not be limited in any way by any limitation of the amount or type of damages, compensation, or benefits payable by or for the CONTRACTOR or any such subcontractor or other person or organization under workers' compensation acts, disability benefit acts, or other employee benefit acts.

6.15 Contractor's Daily Reports

- A. The CONTRACTOR shall complete a daily report indicating manpower, major equipment, subcontractors, weather conditions, etc., involved in the performance of the WORK. The daily report shall be completed on forms prepared by the CONTRACTOR and acceptable to the CITY, and shall be submitted to the CITY'S REPRESENTATIVE at the conclusion of each workday.

6.16 Assignment of Contract

- A. The CONTRACTOR shall not assign, sublet, sell, transfer, or otherwise dispose of the Contract or any portion thereof, or its right, title, or interest therein, or obligations thereunder, without the written consent of the CITY except as imposed by law. If the CONTRACTOR violates this provision, the Contract may be terminated at the option of the CITY. In such event, the CITY shall be relieved of all liability and obligations to the CONTRACTOR and to its assignee or transferee, growing out of such termination.

ARTICLE 7 -- OTHER WORK

7.1 Related Work at Site

- A. The CITY may perform other work related to the Project at the site by the CITY'S own forces, have other work performed by utility companies, or let other direct contracts therefore which may contain General Conditions similar to these. If the fact that such other work is to be performed was not noted in the Construction Documents, written notice thereof will be given to the CONTRACTOR prior to starting any such other work.
- B. The CONTRACTOR shall afford each utility company and other contractors who are a party to such a direct contract (or the CITY, if the CITY is performing the additional work with the CITY'S employees) proper and safe access to the site and a reasonable opportunity for the introduction and storage of materials and equipment and the execution of such work, and shall properly connect and coordinate the WORK with theirs. The CONTRACTOR shall do all cutting, fitting, and patching of the WORK that may be required to make its several parts come together properly and integrate with such other work. The CONTRACTOR shall not endanger any work of others by cutting, excavating, or otherwise altering their work and will only cut or alter their work with the written consent of the CITY and the others whose work will be affected.

SECTION 00700

WELL 7 PUMP HOUSE IMPROVEMENTS, CIP PW 23-05
CUPCCAA INFORMAL BID SOLICITATION

GENERAL CONDITIONS

- C. If any part of the CONTRACTOR'S work depends for proper execution or results upon the work of any such other contractor or utility company (or CITY), the CONTRACTOR shall inspect and report to the CITY'S REPRESENTATIVE in writing any delays, defects, or deficiencies in such work that render it unavailable or unsuitable for such proper execution and results. The CONTRACTOR'S failure to report such delays, defects, or deficiencies will constitute an acceptance of the other work as fit and proper for integration with the CONTRACTOR'S work except for latent or non-apparent defects and deficiencies in the other work.

7.2 Coordination

- A. If the CITY contracts with others for the performance of other work on the Project at the site, the person or organization who will have authority and responsibility for coordination of the activities among the various prime contractors will be identified in the Supplementary Conditions, and the specific matters to be covered by such authority and responsibility will be itemized and the extent of such authority and responsibilities will be provided in the Supplementary Conditions. Unless otherwise provided in the Supplementary Conditions, neither the CITY nor the ENGINEER shall have any authority or responsibility in respect of such coordination.

ARTICLE 8 -- CITY'S RESPONSIBILITIES

8.1 Communications

- A. The CITY shall issue all its communications to the CONTRACTOR through the CITY'S REPRESENTATIVE.

8.2 Payments

- A. The CITY shall make payments to the CONTRACTOR as provided in Paragraphs 14.5 and 14.8.

8.3 Lands, Easements, And Surveys

- A. The CITY'S duties in respect of providing lands and easements and providing engineering surveys to establish reference points are set forth in Paragraphs 4.1. The CITY shall identify and make available to the CONTRACTOR copies of reports of explorations and tests of subsurface conditions at the site and in existing structures, which have been utilized by the ENGINEER in preparing the Drawings and Technical Specifications.

8.4 Change Orders

- A. The CITY shall execute Change Orders as indicated in Paragraph 10.1D.

SECTION 00700

8.5 Inspections and Tests

- A. The CITY'S responsibility in respect of certain inspections, tests, and approvals is set forth in Paragraph 13.3B.

8.6 Suspension of Work

- A. In connection with the CITY'S right to stop work or suspend work, see Paragraphs 13.4 and 15.1. Paragraphs 15.2 and 15.3 deal with the CITY'S right to terminate services of the CONTRACTOR under certain circumstances.

ARTICLE 9 – CITY'S REPRESENTATIVE/ENGINEER'S STATUS DURING CONSTRUCTION

9.1 City's Representative

- A. The CITY'S REPRESENTATIVE is the person, firm or corporation assigned to be the CITY'S representative during the construction period as set forth in the Supplementary Conditions. The duties and responsibilities and the limitations of authority of the CITY'S REPRESENTATIVE during construction are set forth in the Supplementary Conditions.

9.2 Visits to Site

- A. The CITY'S REPRESENTATIVE and/or the ENGINEER may make visits to the site during construction to observe the progress and quality of the WORK and to determine, in general, if the WORK is proceeding in accordance with the Construction Documents. The CITY'S REPRESENTATIVE and/or the ENGINEER is not required to make exhaustive or continuous on-site inspections to check the quality or quantity of the WORK. The CITY'S REPRESENTATIVE and/or the ENGINEER shall not, during such visits or as a result of such observations of the CONTRACTOR'S work in progress, supervise, direct, or have control over the CONTRACTOR'S work.

9.3 Project Engineer

- A. The ENGINEER may furnish a Project Engineer to assist in observing the performance of the WORK. The Project Engineer is the ENGINEER'S agent.

9.4 Clarifications and Interpretations

- A. The ENGINEER, through the CITY'S REPRESENTATIVE, will issue with reasonable promptness such written clarifications or interpretations of the requirements of the Construction Documents (in the form of Drawings or otherwise) as the ENGINEER may determine necessary, which shall be consistent with or reasonably inferable from the overall intent of the Construction Documents.

SECTION 00700

9.5 Authorized Variations in Work

- A. The CITY'S REPRESENTATIVE and/or the ENGINEER may authorize minor variations in the WORK from the requirements of the Construction Documents, which do not involve an adjustment in the Contract Price or the Contract Time and are consistent with the overall intent of the Construction Documents. These may be accomplished by a Field Order issued through the CITY'S REPRESENTATIVE and will require the CONTRACTOR to perform the work involved promptly. If the CONTRACTOR believes that a Field Order justifies an increase in the Contract Price or an extension of the Contract Time and the parties are unable to agree as to the amount or extent thereof, the CONTRACTOR may make a claim therefore as provided in Article 11 or 12.

9.6 Rejecting Defective Work

- A. The CITY'S REPRESENTATIVE has authority to reject work, which the CITY'S REPRESENTATIVE and/or ENGINEER believes to be defective, and also has authority to require special inspection or testing of the WORK as provided in Paragraph 13.3G, whether or not the WORK is fabricated, installed, or completed.

9.7 Contractor Submittals, Change Orders, and Payments

- A. In accordance with the procedures set forth in the General Requirements, the CITY'S REPRESENTATIVE and/or the ENGINEER will review all CONTRACTOR submittals, including shop drawings, samples, substitutes, or "or equal" items, etc., in order to determine if the items covered by the submittals will, after installation or incorporation in the WORK, conform to the requirements of the Construction Documents and be compatible with the design concept of the completed project as a functioning whole as indicated by the Construction Documents. The CITY'S and the ENGINEER'S review shall not extend to means, methods, techniques, sequences or procedures of construction or to safety precautions or programs incident thereto.
- B. In connection with the ENGINEER'S responsibilities as to Change Orders, see Articles 10, 11, and 12.
- C. In connection with the ENGINEER'S responsibilities in respect of Applications for Payment, see Article 14.

9.8 Decisions on Disputes

- A. The CITY'S REPRESENTATIVE will be the initial interpreter of the requirements of the Construction Documents and judge of the acceptability of the WORK there under. Claims, disputes, and other matters relating to the acceptability of the WORK; the interpretation of the requirements of the Construction Documents pertaining to the performance of the WORK; and those claims under Articles 11 and 12 in respect to changes in the Contract Price or Contract Time will be referred initially to the CITY'S REPRESENTATIVE in writing with a request for formal decision in accordance with this paragraph, which the CITY will render in writing within 30 days of receipt of the

SECTION 00700

request. Written notice of each such claim, dispute, and other matter will be delivered by the CONTRACTOR to the CITY'S REPRESENTATIVE promptly but in no event later than 30 days after the occurrence of the event giving rise thereto. Written supporting data will be submitted to the CITY'S REPRESENTATIVE within 30 days after such occurrence unless the CITY allows an additional period of time to ascertain more accurate data in support of the claim.

- B. When functioning as arbiter and judge, the ENGINEER shall not show partiality to the CITY or the CONTRACTOR and shall not be liable in connection with any interpretation or decision rendered in good faith in such capacity. The rendering of a decision by the ENGINEER with respect to any such claim, dispute, or other matter (except any which have been waived by the making or acceptance of final payment as provided in Paragraph 14.12) will be a condition precedent to any exercise by the CITY or the CONTRACTOR of such rights or remedies as either may otherwise have under the Construction Documents or by Law or Regulations in respect of any such claim, dispute, or other matter.
- C. All contracts between the Contractor and his subcontractors and suppliers regardless of tier shall include a provision that subcontractors and suppliers shall be bound to the Contractor to the same extent that the Contractor is bound to the CITY by all terms and provisions of the Contract, including this arbitration provision.

9.9 Limitation on Engineer's Responsibilities

- A. Neither the ENGINEER'S authority to act under this Article 9 or other provisions of the Construction Documents nor any decision made by the ENGINEER in good faith whether to exercise such authority shall give rise to any duty or responsibility of the ENGINEER to the CONTRACTOR, any Subcontractor, any Supplier, any surety for any of them, or any other person or organization performing any of the WORK.
- B. Whenever in the Construction Documents the terms "as ordered," "as directed," "as required," "as allowed," "as reviewed," "as approved," or terms of like effect or import are used, or the adjectives "reasonable," "suitable," "acceptable," "proper," or "satisfactory" or adjectives of like effect or import are used to describe a requirement, direction, review, or judgment of the ENGINEER and CITY as to the WORK, it is intended that such requirement, direction, review, or judgment will be solely to evaluate the WORK for compliance with the requirements of the Construction Documents, and conformance with the design concept of the completed Project as a functioning whole as indicated by the Construction Documents, unless there is a specific statement indicating otherwise. The use of any such term or adjective shall not be effective to assign to the ENGINEER and the CITY any duty or authority to supervise or direct the performance of the WORK or any duty or authority to undertake responsibility contrary to the provisions of Paragraph 9.9C or 9.9D.
- C. The ENGINEER and the CITY will not have authority over or be responsible for the CONTRACTOR'S means, methods, techniques, sequences, or procedures of

SECTION 00700

construction, or the safety precautions and programs incident thereto, or for any failure of the CONTRACTOR to comply with Laws and Regulations, applicable to the performance of the WORK. The ENGINEER and CITY will not be responsible for the CONTRACTOR'S failure to perform the WORK in accordance with the Construction Documents.

- D. The ENGINEER and CITY will not be responsible for the acts or omissions of the CONTRACTOR nor of any subcontractor, supplier, or any other person or organization performing any of the WORK.

ARTICLE 10 -- CHANGES IN THE WORK

10.1 General

- A. Without invalidating the Contract and without notice to any surety, the CITY may at any time or from time to time, order additions, deletions, or revisions in the WORK; these will be authorized by a written Field Order and/or a Change Order issued by the CITY based on recommendations by the Engineer. Upon receipt of any such document, the CONTRACTOR shall promptly proceed with the work involved, which will be performed under the applicable conditions of the Construction Documents.
- B. If the CITY and the CONTRACTOR are unable to agree as to the extent, if any, of an increase or decrease in the Contract Price or an extension or shortening of the Contract Time that should be allowed as a result of a Field Order, a claim may be made therefore as provided in Articles 11 or 12.
- C. The CONTRACTOR shall not be entitled to an increase in the Contract Price nor an extension of the Contract Time with respect to any work performed that is not required by the Construction Documents as amended, modified, supplemented by Change Order, except in the case of an emergency and except in the case of uncovering work as provided in Paragraph 13.3G.
- D. The CITY and the CONTRACTOR shall execute appropriate Change Orders covering:
1. Changes in the WORK, which are ordered/recommended by the ENGINEER and agreed to by CITY pursuant to Paragraph 10.1A;
 2. Changes required because of acceptance of defective work under Paragraph 13.7;
 3. Changes in the Contract Price or Contract Time which are agreed to by the parties;
or
 4. Any other changes agreed to by the parties.
- E. If notice of any change is required by the provisions of any Bond to be given to a surety, the giving of any such notice will be the CONTRACTOR'S responsibility, and the amount of each applicable Bond shall be adjusted accordingly.

SECTION 00700

10.2 Allowable Quantity Variations

- A. In the event of an increase or decrease in bid item quantity of a unit price contract, the total amount of work actually done or materials or equipment furnished shall be paid for according to the unit price established for such work under the Construction Documents, wherever such unit price has been established; provided, that an adjustment in the Contract Price may be made for changes which result in an increase or decrease in the quantity of any unit price bid item of the WORK in excess of 25 percent.
- B. In the event a part of the WORK is to be entirely eliminated and no lump sum or unit price is named in the Construction Documents to cover such eliminated work, the price of the eliminated work shall be agreed upon in writing by the CITY and the CONTRACTOR. If the CITY and the CONTRACTOR fail to agree upon the price of the eliminated work, said price shall be determined in accordance with the provisions of Article 11.

ARTICLE 11 -- CHANGE OF CONTRACT PRICE

11.1 General

- A. The Contract Price constitutes the total compensation payable to the CONTRACTOR for performing the WORK. All duties, responsibilities, and obligations assigned to or undertaken by the CONTRACTOR shall be at its expense without change in the Contract Price.
- B. The Contract Price shall only be changed by a Change Order. Any claim for an increase in the Contract Price shall be based on written notice delivered by the CONTRACTOR to the CITY promptly (but in no event later than 30 days) after the occurrence of the event giving rise to the claim and stating the general nature of the claim. Notice of the amount of the claim with supporting data shall be delivered within 60 days after such occurrence (unless the CITY allows an additional period of time to ascertain more accurate data in support of the claim) and shall be accompanied by the CONTRACTOR'S written statement that the amount claimed covers all known amounts (direct, indirect, and consequential) to which the CONTRACTOR is entitled as a result of the occurrence of said event. All claims for adjustment in the Contract Price shall be determined by the CITY in accordance with Paragraph 9.8A if the CITY and the CONTRACTOR cannot otherwise agree on the amount involved. No claim for an adjustment in the Contract Price will be valid if not submitted in accordance with this Paragraph 11.1B.
- C. The value of any work covered by a Change Order or of any claim for an increase or decrease in the Contract Price shall be determined in one of the following ways:
 - 1. Where the work involved is covered by unit prices contained in the Construction Documents, by application of unit prices to the quantities of the items involved.
 - 2. By mutual acceptance of a lump sum, which may include an allowance for overhead and profit not necessarily in accordance with Paragraph 11.4.

SECTION 00700

3. On the basis of the cost of work (determined as provided in Paragraphs 11.2 and 11.3) plus a CONTRACTOR'S fee for overhead and profit (determined as provided in Paragraph 11.4).

11.2 Cost of Work (Based On Time and Materials)

- A. General: The CONTRACTOR shall provide an approximate value of any extra work to be performed prior to starting the extra work. The sum of all costs necessarily incurred and paid by the CONTRACTOR for labor, materials, and equipment in the proper performance of extra work. Except as otherwise may be agreed to in writing by the CITY, the cost of work shall be in amounts no higher than those prevailing in the locality of the Project. Whenever any extra work is in progress, for which the definite price has not been agreed on in advance, the CONTRACTOR shall each day, report to the CITY the amount and cost of the labor and material used, and any other expense incurred in such extra work on the preceding day, and no claim for compensation for such extra work will be allowed unless such report shall have been made.
- B. Labor: The cost of labor used in performing extra work by the CONTRACTOR, a subcontractor, or other forces will be the sum of the following:
 1. The actual wages paid plus any employer payments to, or on behalf of workers for fringe benefits including health and welfare, pension, vacation, and similar purposes. The cost of labor may include the wages paid to foremen when determined by the CITY that the services of foremen do not constitute a part of the overhead allowance.
 2. All payment imposed by state and federal laws including, but not limited to, compensation insurance, and social security payments.
 3. The amount paid for subsistence and travel required by collective bargaining agreements, or in accordance with the regular practice of the employer.

At the beginning of the extra work and as later requested by the CITY, the CONTRACTOR shall furnish the CITY proof of labor compensation rates being paid.

- C. Materials: The cost of materials used in performing extra work will be the cost to the purchaser, whether CONTRACTOR or subcontractor, from the supplier thereof, except as the following are applicable:
 1. Trade discounts available to the purchaser shall be credited to the CITY notwithstanding the fact that such discounts may not have been taken by the CONTRACTOR.
 2. For materials secured by other than a direct purchase and direct billing to the purchaser, the cost shall be deemed to be the price paid to the actual supplier as determined by the CITY'S REPRESENTATIVE. Markup except for actual costs incurred in the handling of such materials will not be allowed.

SECTION 00700

WELL 7 PUMP HOUSE IMPROVEMENTS, CIP PW 23-05
CUPCCAA INFORMAL BID SOLICITATION

GENERAL CONDITIONS

3. Payment for materials from sources owned wholly or in part by the purchaser shall not exceed the price paid by the purchaser for similar materials from said sources on extra work items or the current wholesale price for such materials delivered to the work site, whichever price is lower.
 4. If in the opinion of the CITY'S REPRESENTATIVE the cost of material is excessive, or the CONTRACTOR does not furnish satisfactory evidence of the cost of such material, then the cost shall be deemed to be the lowest current wholesale price for the quantity concerned delivered to the work site less trade discount. The CITY reserves the right to furnish materials for the extra work and no claim shall be made by the CONTRACTOR for costs and profit on such materials.
- D. Equipment: The CONTRACTOR will be paid for the use of equipment at the rental rate listed for such equipment specified in the "Labor Surcharge and Equipment Rental Rates" as published by the Department of Transportation. Such rental rate will be used to compute payments for equipment whether the equipment is under the CONTRACTOR'S control, through direct City control, leasing, renting, or another method of acquisition. The rental rate to be applied for use of each item of equipment shall be the rate resulting in the least total cost to the CITY for the total period of use. If it is deemed necessary by the CONTRACTOR to use equipment not listed in the publication specified in the Supplementary Conditions, an equitable rental rate for the equipment will be established by the CITY'S REPRESENTATIVE. The CONTRACTOR may furnish cost data, which might assist the CITY'S REPRESENTATIVE in the establishment of the rental rate.
1. All equipment shall, in the opinion of the CITY'S REPRESENTATIVE, be in good working condition and suitable for the purpose for which the equipment is to be used.
 2. Before construction equipment is used on the extra work, the CONTRACTOR shall plainly stencil or stamp an identifying number thereon at a conspicuous location, and shall furnish to the CITY'S REPRESENTATIVE, in duplicate, a description of the equipment and its identifying number.
 3. Unless otherwise specified, manufacturer's ratings and manufacturer-approved modifications shall be used to classify equipment for the determination of applicable rental rates. Equipment, which has no direct power unit, shall be powered by a unit of at least the minimum rating recommended by the manufacturer.
 4. Individual pieces of equipment or tools having a replacement value of \$100 or less, whether or not consumed by use, shall be considered to be small tools and no payment will be made therefore.
 5. Rental time will not be allowed while equipment is inoperative due to breakdowns.
- E. Equipment on the Work Site: The rental time to be paid for equipment on the work site shall be the time the equipment is in productive operation on the extra work being

SECTION 00700

performed and, in addition, shall include the time required to move the equipment to the location of the extra work and return it to the original location or to another location requiring no more time than that required to return it to its original location; except, that moving time will not be paid if the equipment is used on other than the extra work, even though located at the site of the extra work. Loading and transporting costs will be allowed, in lieu of moving time, when the equipment is moved by means other than its own power, except that no payment will be made for loading and transporting costs when the equipment is used at the site of the extra work on other than the extra work. The following shall be used in computing the rental time of equipment on the work site.

1. When hourly rates are listed, any part of an hour less than 30 minutes of operation shall be considered to be 1/2-hour of operation, and any part of an hour in excess of 30 minutes will be considered one hour of operation.
2. When daily rates are listed, any part of a day less than 4 hours operation shall be considered to be 1/2-day of operation. When CITY-operated equipment is used to perform extra work to be paid for on a time and materials basis, the CONTRACTOR will be paid for the equipment and operator, as set forth in Paragraphs (3), (4), and (5), following.
3. Payment for the equipment will be made in accordance with the provisions in Paragraph 11.2D, herein.
4. Payment for the cost of labor and subsistence or travel allowance will be made at the rates paid by the CONTRACTOR to other workers operating similar equipment already on the work site, or in the absence of such labor, established by collective bargaining agreements for the type of workmen and location of the extra work, whether or not the operator is actually covered by such an agreement. A labor surcharge will be added to the cost of labor described herein in accordance with the provisions of Paragraph 11.2B, herein, which surcharge shall constitute full compensation for payments imposed by state and federal laws and all other payments made to or on behalf of workers other than actual wages.
5. To the direct cost of equipment rental and labor, computed as provided herein, will be added the allowances for equipment rental and labor as provided in Paragraph 11.4, herein.

11.3 Special Services

- A. Special work or services are defined as that work characterized by extraordinary complexity, sophistication, or innovation or a combination of the foregoing attributes which are unique to the construction industry. The following may be considered by the CITY'S REPRESENTATIVE in making estimates for payment for special services:
 1. When the CITY'S REPRESENTATIVE and the CONTRACTOR, by agreement, determine that a special service or work is required which cannot be performed by the forces of the CONTRACTOR or those of any of its subcontractors, the special

SECTION 00700

service or work may be performed by an entity especially skilled in the work to be performed. After validation of invoices and determination of market values by the CITY'S REPRESENTATIVE, invoices for special services or work based upon the current fair market value thereof may be accepted without complete itemization of labor, material, and equipment rental costs.

2. When the CONTRACTOR is required to perform work necessitating special fabrication or machining process in a fabrication or a machine shop facility away from the job site, the charges for that portion of the work performed at the off-site facility may, by agreement, be accepted as a special service and accordingly, the invoices for the work may be accepted without detailed itemization.
3. All invoices for special services will be adjusted by deducting all trade discounts offered or available, whether the discounts were taken or not. In lieu of the allowances for overhead and profit specified in Paragraph 11.4, herein, an allowance of 5 percent will be added to invoices for special services.

B. All work performed hereunder shall be subject to all of the provisions of the Construction Documents and the CONTRACTOR'S sureties shall be bound with reference thereto as under the original Contract. Copies of all amendments to surety bonds or supplemental surety bonds shall be submitted to the CITY'S REPRESENTATIVE for review prior to the performance of any work hereunder.

11.4 Contractor's Fee

A. Extra work ordered on the basis of time and materials will be paid for at the actual necessary cost as determined by the CITY'S REPRESENTATIVE, plus allowances for overhead and profit. For extra work involving a combination of increases and decreases in the WORK the actual necessary cost will be the arithmetic sum of the additive and deductive costs. The allowance for overhead and profit shall include full compensation for superintendence, bond and insurance premiums, taxes, office expense, and all other items of expense or cost not included in the cost of labor, materials, or equipment provided for under Paragraphs 11.2B, C, and D, herein including extended overhead and home office overhead. The allowance for overhead and profit will be made in accordance with the following schedule:

<u>Actual Necessary Cost</u>	<u>Overhead and Profit Allowance</u>
Labor	15percent
Materials	10percent
Equipment	10 percent
Subcontractor	5 percent

B. It is understood that labor, materials, and equipment may be furnished by the CONTRACTOR or by the subcontractor on behalf of the CONTRACTOR. When all or any part of the extra work is performed by a subcontractor, the allowance specified herein shall be applied to the labor, materials, and equipment costs of the subcontractor, to which the CONTRACTOR may add 5 percent of the subcontractor's total cost for the

SECTION 00700

extra work. Regardless of the number of hierarchical tiers of subcontractors, the 5 percent increase above the subcontractor's total cost which includes the allowances for overhead and profit specified herein may be applied one time only for each separate work transaction.

ARTICLE 12 -- CHANGE OF CONTRACT TIME

12.1 General

- A. The Contract Time may only be changed by a Change Order. Any claim for an extension of the Contract Time shall be based on written notice delivered by the CONTRACTOR to the CITY'S REPRESENTATIVE promptly (but in no event later than 30 days) after the occurrence of the event giving rise to the claim and stating the general nature of the claim. Notice of the extent of the claim with supporting data shall be delivered within 60 days after such occurrence (unless the CITY'S REPRESENTATIVE allows an additional period of time to ascertain more accurate data in support of the claim) and shall be accompanied by the CONTRACTOR'S written statement that the adjustment claimed is the entire adjustment to which the CONTRACTOR has reason to believe it is entitled as a result of the occurrence of said event. All claims for adjustment in the Contract Time shall be determined by the CITY'S REPRESENTATIVE in accordance with Paragraph 9.8 if the CITY and the CONTRACTOR cannot otherwise agree. No claim for an adjustment in the Contract Time will be valid if not submitted in accordance with the requirements of this Paragraph 12.1A.
- B. The Contract Time will be extended in an amount equal to time lost due to delays beyond the control of the CONTRACTOR provided that such time lost affects the critical path as shown on the CPM schedule if a claim is made therefore as provided in Paragraph 12.1A. Such delays shall include: acts or neglect by the CITY or others performing additional work as contemplated by Article 7, or by acts of God or of the public enemy, fire, floods, epidemics, quarantine restrictions, strikes, labor disputes, sabotage or freight embargoes.
- C. All time limits stated in the Construction Documents are of the essence of the Contract.

12.2 Extensions of Time for Delay Due to Inclement Weather

- A. Inclement weather is any weather condition or conditions resulting immediately there from, causing the CONTRACTOR to suspend construction operations or preventing the CONTRACTOR from proceeding with at least 75 percent of the normal labor and equipment force engaged on the work.
- B. Should the CONTRACTOR prepare to begin work at the regular starting time at the beginning of any regular work shift on any day on which inclement weather, or the conditions resulting from the weather, or the condition of the WORK prevents work from beginning at the usual starting time and the crew is dismissed as a result thereof, the CONTRACTOR will not be charged for a working day whether or not conditions change

SECTION 00700

thereafter during said day and the major portion of the day could be considered to be suitable for such construction operations.

- C. The CONTRACTOR shall base its construction schedule upon the inclusion of the number of days of inclement weather specified in paragraph entitled "Inclement weather delays" of the Supplementary Conditions. No extension of the Contract Time due to inclement weather will be considered until after the said number of days of inclement weather has been reached. However, no reduction in Contract Time will be made if said number of days of inclement weather is not reached.

ARTICLE 13 -- WARRANTY AND GUARANTEE; TESTS AND INSPECTIONS; CORRECTION, REMOVAL, OR ACCEPTANCE OF DEFECTIVE WORK

13.1 Warranty and Guarantee

- A. The CONTRACTOR warrants and guarantees to the CITY and the ENGINEER that all work will be in accordance with the Construction Documents and will not be defective. Prompt notice of defects known to the CITY and ENGINEER shall be given to the CONTRACTOR. All defective work, whether or not in place, may be rejected, corrected, or accepted as provided in this Article 13.

13.2 Access to Work

- A. The CITY'S REPRESENTATIVE, ENGINEER, other representatives of the CITY, testing agencies, and governmental agencies with jurisdictional interests shall have access to the WORK at reasonable times for their observation, inspections, and testing. The CONTRACTOR shall provide proper and safe conditions for such access.

13.3 Tests and Inspections

- A. The CONTRACTOR shall give the CITY'S REPRESENTATIVE timely notice of readiness of the WORK for all required inspections, tests, or approvals.
- B. If Laws or Regulations of the CITY, or any public body having jurisdiction other than the CITY, require any work to specifically be inspected, tested, or approved, the CONTRACTOR shall pay all costs in connection therewith. The CONTRACTOR shall be responsible for and shall pay all costs in connection with testing the work for compliance with the Construction Documents unless stated otherwise in the Supplementary Conditions. The CONTRACTOR shall also be responsible for and shall pay all costs in connection with any inspection or testing required in connection with the CITY'S or the ENGINEER'S acceptance of a Supplier of materials or equipment proposed as a substitution or (or-equal) to be incorporated in the WORK, or of materials or equipment submitted for review prior to the CONTRACTOR'S purchase thereof for incorporation in the WORK.
- C. The CITY'S REPRESENTATIVE will make, or have made, such inspections and tests as the CITY'S REPRESENTATIVE deems necessary to see that the WORK is being accomplished in accordance with the requirements of the Construction Documents.

SECTION 00700

Unless otherwise specified in the Supplementary Conditions, the cost of such inspection and testing will be borne by the CITY. In the event such inspections or tests reveal non-compliance with the requirements of the Construction Documents, the CONTRACTOR shall bear the cost of corrective measures deemed necessary by the CITY'S REPRESENTATIVE, as well as the cost of subsequent re-inspection and retesting. Neither observations by the CITY'S REPRESENTATIVE nor inspections, tests, or approvals by others shall relieve the CONTRACTOR from the CONTRACTOR'S obligation to perform the WORK in accordance with the Construction Documents.

- D. All inspections, tests, or approvals other than those required by Laws or Regulations of any public body having jurisdiction shall be performed by organizations acceptable to the CITY'S REPRESENTATIVE.
- E. If any work (including the work of others) that is to be inspected, tested, or approved is covered without written concurrence of the CITY'S REPRESENTATIVE, it must, if requested by the CITY'S REPRESENTATIVE, be uncovered for observation. Such uncovering shall be at the CONTRACTOR'S expense unless the CONTRACTOR has given the CITY'S REPRESENTATIVE timely notice of the CONTRACTOR'S intention to perform such test or to cover the same and the CITY'S REPRESENTATIVE has not acted with reasonable promptness in response to such notice.
- F. If any work is covered contrary to the written request of the CITY'S REPRESENTATIVE, it must, if requested by the CITY'S REPRESENTATIVE, be uncovered for the CITY'S REPRESENTATIVE observation and replaced at the CONTRACTOR'S expense.
- G. If the CITY'S REPRESENTATIVE considers it necessary or advisable that covered work be observed by the CITY'S REPRESENTATIVE or inspected or tested by others, the CONTRACTOR, at the CITY'S REPRESENTATIVE request, shall uncover, expose, or otherwise make available for observation, inspection, or testing as the CITY'S REPRESENTATIVE may require, that portion of the WORK in question, furnishing all necessary labor, material, and equipment. If it is found that such work is defective, the CONTRACTOR shall bear all direct, indirect, and consequential costs and damages of such uncovering, exposure, observation, inspection, and testing and of satisfactory reconstruction, including but not limited to fees and charges of engineers, architects, attorneys, and other professionals. However, if such work is not found to be defective, the CONTRACTOR shall be allowed an increase in the Contract Price or an extension of the Contract Time, or both, directly attributable to such uncovering, exposure, observation, inspection, testing, and reconstruction; and, if the parties are unable to agree as to the amount or extent thereof, the CONTRACTOR may make a claim therefore as provided in Articles 11 and 12.

13.4 City May Stop the Work

- A. If the WORK is defective, or the CONTRACTOR fails to perform work in such a way that the completed WORK will conform to the Construction Documents, the CITY'S

SECTION 00700

REPRESENTATIVE may order the CONTRACTOR to stop the WORK, or any portion thereof, until the cause for such order has been eliminated; however, this right of the CITY to stop the WORK shall not give rise to any duty on the part of the CITY to exercise this right for the benefit of the CONTRACTOR or any other party.

13.5 Correction or Removal of Defective Work

- A. If required by the CITY'S REPRESENTATIVE, the CONTRACTOR should promptly, either correct all defective work, whether or not fabricated, installed, or completed, or, if the WORK has been rejected by the CITY'S REPRESENTATIVE, remove it from the site and replace it with non-defective work. The CONTRACTOR shall bear all direct, indirect and consequential costs and damages of such correction or removal, including but not limited to fees and charges of engineers, architects, attorneys, and other professionals made necessary thereby.

13.6 One Year Correction Period

- A. If within one year after the date of Substantial Completion/Notice of Completion or such longer period of time as may be prescribed by Laws or Regulations or by the terms of any applicable special guarantee required by the Construction Documents or by any specific provision of the Construction Documents, any work is found to be defective in the CITY'S sole and absolute discretion, the CONTRACTOR shall promptly, without cost to the CITY and in accordance with CITY'S written notification, either correct such defective work, or, if it has been rejected by the CITY, remove it from the site and replace it with non-defective work. If the CONTRACTOR does not promptly comply with the such notification, or in an emergency where delay would cause serious risk of loss or damage, the CITY'S REPRESENTATIVE may have the defective work corrected or the rejected work removed and replaced, and all direct, indirect, and consequential costs and damages of such removal and replacement including but not limited to fees and charges of engineers, architects, attorneys and other professionals will be paid by the CONTRACTOR.

13.7 Acceptance of Defective Work

- A. The City may accept any work performed defectively. Any such acceptance of defective work shall not waive the City's right to enforce a one-year correction period listed above in Section 13.6(A) unless such a waiver is expressly included in the written acceptance of defective work by the City and the City receives an agreed upon decrease in the contract price in exchange for the release of the above referenced one-year warranty on any defective work accepted.
- B. If, instead of requiring correction or removal and replacement of defective work, the CITY prefers to accept the work, the CITY may do so. The CONTRACTOR shall bear all direct, indirect, and consequential costs attributable to the CITY'S REPRESENTATIVE evaluation of and determination to accept such defective work. If any such acceptance occurs prior to final payment, a Change Order will be issued

SECTION 00700

incorporating the necessary revisions in the Construction Documents with respect to the WORK, and the CITY shall be entitled to an appropriate decrease in the Contract Price.

ARTICLE 14 -- PAYMENTS TO CONTRACTOR AND COMPLETION

14.1 Schedule of Values (Lump Sum Price Breakdown)

- A. The CONTRACTOR shall provide a Schedule of Values (lump sum price breakdown) for all "Lump Sum" items of work. The Schedule of Values shall serve as the basis for progress payments and will be incorporated into a form of Application for Payment acceptable to the CITY'S REPRESENTATIVE.

14.2 Unit Price Bid Schedule

- A. Progress payments on account of Unit Price work will be based on the number of units completed.

14.3 Application for Progress Payment

- A. Unless otherwise prescribed by law, on the 25th of each month, the CONTRACTOR shall submit to the CITY'S REPRESENTATIVE for review, an Application for Payment filled out and signed by the CONTRACTOR covering the WORK completed as of the date of the Application and accompanied by such supporting documentation as is required by the Construction Documents.
- B. The Application for Payment shall identify, as a sub-total, the amount of the CONTRACTOR'S total earnings to date, plus the value of materials stored at the site which have not yet been incorporated in the WORK, and less a deductive adjustment for materials installed which were not previously incorporated in the WORK, but for which payment was allowed under the provisions for payment for materials stored at the site, but not yet incorporated in the WORK.
- C. The net payment due to the CONTRACTOR shall be the above-mentioned subtotal from which shall be deducted the amount of retainage specified below and the total amount of all previous payments made to the CONTRACTOR.
 - 1. The CITY may retain 5 percent of each approved progress payment until the work is completed and accepted and release of retainage and other deduction as described in Section 14.10. occurs.
- D. The value of materials stored at the site shall be an amount equal to the specified percent of the value of such materials as set forth in the Supplementary Conditions. Said amount shall be based upon the value of all acceptable materials and equipment not incorporated in the WORK but delivered and suitably stored at the site or at another location agreed to in writing; provided, each such individual item has a value of more than \$5000 and will become a permanent part of the WORK. The Application for Payment shall also be accompanied by a bill of sale, invoice, or other documentation warranting that the

SECTION 00700

CONTRACTOR has received the materials and equipment free and clear of all liens, charges, security interests, and encumbrances (which are hereinafter in these General Conditions referred to as "Liens") and evidence that the materials and equipment are covered by appropriate property insurance and other arrangements to protect the CITY'S interest therein, all of which will be satisfactory to the CITY.

14.4 Contractor's Warranty of Title

- A. The CONTRACTOR warrants and guarantees that title to all work, materials, and equipment covered by an Application for Payment, whether incorporated in the WORK or not, will pass to the CITY no later than the time of final payment free and clear of all liens.

14.5 Review of Applications for Progress Payment

- A. The CITY'S REPRESENTATIVE will, within 7 days after receipt of each Application for Payment, either indicate in writing a recommendation of payment or return the Application to the CONTRACTOR indicating in writing the CITY's reasons for refusing to recommend payment. In the latter case, the CONTRACTOR may make the necessary corrections and resubmit the Application. Thirty days after presentation of the Application for Payment with the CITY recommendation, the amount recommended will (subject to the provisions of Paragraph 14.5B) become due and when due will be paid by the CITY to the CONTRACTOR.
- B. The CITY may refuse to make payment of the full amount requested by the CONTRACTOR because claims have been made against the CITY on account of the CONTRACTOR'S performance of the WORK or Liens have been filed in connection with the WORK or there are other items entitling the CITY to a credit against the amount recommended, but the CITY will give the CONTRACTOR written notice within 7 days stating the reasons for such action.

14.6 Partial Completion

- A. The CITY shall have the right to utilize or place into service any item of equipment or other usable portion of the WORK prior to completion of the WORK. Whenever the CITY plans to exercise said right, the CONTRACTOR will be notified in writing by the CITY, identifying the specific portion or portions of the WORK to be so utilized or otherwise placed into service.
- B. It shall be understood by the CONTRACTOR that until such written notification is issued, all responsibility for care and maintenance of all items or portions of the WORK to be partially utilized shall be borne by the CONTRACTOR. Upon issuance of said written notice of partial completion, the CITY will accept responsibility for the protection and maintenance of all such items or portions of the WORK described in the written notice.

SECTION 00700

- C. The CONTRACTOR shall retain full responsibility for satisfactory completion of the WORK, regardless of whether a portion thereof has been partially utilized by the CITY and the CONTRACTOR'S one year correction period shall commence only after the date of Substantial Completion/Notice of Completion for the WORK.

14.7 Substantial Completion

- A. When the CONTRACTOR considers the WORK ready for its intended use the CONTRACTOR shall notify the CITY and the ENGINEER in writing that the WORK is substantially complete and request that the CITY'S REPRESENTATIVE prepare a Certificate of Substantial Completion/Notice of Completion. Within a reasonable time thereafter, the CONTRACTOR and the CITY'S REPRESENTATIVE shall make an inspection of the WORK to determine the status of completion. If the CITY'S REPRESENTATIVE does not consider the WORK substantially complete, the CITY'S REPRESENTATIVE will notify the CONTRACTOR in writing giving the reasons therefore. If the CITY'S REPRESENTATIVE considers the WORK substantially complete, the CITY'S REPRESENTATIVE will prepare for execution and recordation the Certificate of Substantial Completion/Notice of Completion signed by the CITY and CONTRACTOR, which shall fix the date of Substantial Completion/Notice of Completion. As applicable, there shall be attached to the Certificate/Notice a list of items to be completed or corrected before final payment.

14.8 Final Application for Payment

- A. After the CONTRACTOR has completed all correction work referred to in Paragraph 14.7 and delivered all maintenance and operating instructions, schedules, guarantees, Bonds, certificates of inspection, marked-up record documents (as provided in the General Requirements) and other documents, all as required by the Construction Documents, and after the ENGINEER has indicated that the WORK is acceptable, the CONTRACTOR may make application for final payment following the procedure for progress payments. The final Application for Payment shall be accompanied by all documentation called for in the Construction Documents, together with complete and legally effective releases or waivers (satisfactory to the CITY) of all liens arising out of or filed in connection with the WORK.

14.9 Final Payment and Acceptance

- A. If, on the basis of the CITY'S REPRESENTATIVE'S observation of the WORK during construction and final inspection, and the CITY'S REPRESENTATIVE'S review of the final Application for Payment and accompanying documentation, all as required by the Construction Documents, the CITY'S REPRESENTATIVE is satisfied that the WORK has been completed and the CONTRACTOR'S other obligations under the Construction Documents have been fulfilled, the CITY'S REPRESENTATIVE will, within 14 days after receipt of the final Application for Payment, indicate in writing the CITY'S REPRESENTATIVE'S recommendation of payment and present the Application to the CITY for payment.

SECTION 00700

- B. After acceptance of the WORK by the CITY'S governing body, the CITY will make final payment to the CONTRACTOR of the amount remaining after deducting all prior payments and all amounts to be kept or retained under the provisions of the Construction Documents, including the following item:

Two times the value of outstanding items of correction work or punch list items indicated on the Certificate of Substantial Completion/Notice of Completion as being yet uncompleted or uncorrected, as applicable. All such work shall be completed or corrected to the satisfaction of the CITY within the time stated on the Certificate of Substantial Completion/Notice of Completion; otherwise the CONTRACTOR does hereby waive any and all claims to all monies withheld by the CITY to cover the value of all such uncompleted or uncorrected items.

14.10 Release of Retainage and Other Deductions

- A. After executing the necessary documents to initiate the lien period, and not more than 45 days thereafter (based on a 30-day lien filing period and 15-day processing time), the CITY will release to the CONTRACTOR the retainage funds withheld pursuant to the Contract, less any deductions to cover pending claims against the CITY pursuant to Paragraph 14.5B.
- B. After filing of the necessary documents to initiate the lien period, the CONTRACTOR shall have 30 days to complete any outstanding items of correction work remaining to be completed or corrected as listed on a final punch list made a part of the Certificate of Substantial Completion/Notice of Completion. Upon expiration of the 45 days, referred to in Paragraph 14.10A, the amounts withheld pursuant to the provisions of Paragraph 14.9B herein, for all remaining work items will be returned to the CONTRACTOR; provided, that said work has been completed or corrected to the satisfaction of the CITY within said 30 days. Otherwise, the CONTRACTOR does hereby waive any and all claims for all monies withheld by the CITY under the Contract to cover 2 times the value of such remaining uncompleted or uncorrected items.

14.11 Contractor's Continuing Obligation

- A. The CONTRACTOR'S obligation to perform and complete the WORK in accordance with the Construction Documents shall be absolute. Neither recommendation of any progress or final payment by the CITY, nor the issuance of a Certificate of Substantial Completion/Notice of Completion, nor any payment by the CITY to the CONTRACTOR under the Construction Documents, nor any use or occupancy of the WORK or any part thereof by the CITY, nor any act of acceptance by the CITY nor any failure to do so, nor any review of a Shop Drawing or sample submittal, will constitute an acceptance of work not in accordance with the Construction Documents or a release of the CONTRACTOR'S obligation to perform the WORK in accordance with the Construction Documents.

SECTION 00700

14.12 Final Payment Terminates Liability of City

- A. Final payment is defined as the last progress payment made to the CONTRACTOR for earned funds, less retainage as applicable, less deductions listed in Paragraph 14.9B herein. The acceptance by the CONTRACTOR of the final payment referred to in Paragraph 14.9 herein, shall be a release of the CITY and its agents from all claims of liability to the CONTRACTOR for anything done or furnished for, or relating to, the WORK or for any act or neglect of the CITY or of any person relating to or affecting the WORK, except demands against the CITY for the remainder, if any, of the amounts kept or retained under the provisions of Paragraph 14.9 herein; and excepting pending, unresolved claims filed prior to the date of the Certificate of Substantial Completion/Notice of Completion.

ARTICLE 15 -- SUSPENSION OF WORK AND TERMINATION

15.1 Suspension of Work by City

- A. The CITY, may, at any time and without cause, suspend the WORK or any portion thereof for a period of not more than 90 days by notice in writing to the CONTRACTOR. The CONTRACTOR shall resume the WORK on receipt from the CITY'S REPRESENTATIVE of a notice of resumption of work. The CONTRACTOR shall be allowed an increase in the Contract Price or an extension of the Contract Time, or both, directly attributable to any suspension if the CONTRACTOR makes an approved claim therefore as provided in Articles 11 and 12.

15.2 Termination of Contract by City (Contractor Default)

- A. In the event of default by the CONTRACTOR, the CITY may give 10 days' written notice to the CONTRACTOR of CITY'S intent to terminate the Contract and provide the CONTRACTOR an opportunity to remedy the conditions constituting the default. It shall be considered a default by the CONTRACTOR whenever CONTRACTOR shall: (1) declare bankruptcy, become insolvent, or assign its assets for the benefit of its creditors; (2) fail to provide materials or workmanship meeting the requirements of the Construction Documents; (3) disregard or violate provisions of the Construction Documents or CITY'S REPRESENTATIVE'S instructions; (4) fail to prosecute the WORK according to the approved progress schedule; or, (5) fail to provide a qualified superintendent, competent workmen, or materials or equipment meeting the requirements of the Construction Documents. If the CONTRACTOR fails to remedy the conditions constituting default within the time allowed, the CITY may then issue the Notice of Termination.
- B. In the event the Contract is terminated in accordance with Paragraph 15.2A, herein, the CITY may take possession of the WORK and may complete the WORK by whatever method or means the CITY may select. The cost of completing the WORK shall be deducted from the balance which would have been due the CONTRACTOR had the Contract not been terminated and the WORK completed in accordance with the Construction Documents. If such cost exceeds the balance, which would have been due,

SECTION 00700

the CONTRACTOR shall pay the excess amount to the CITY. If such cost is less than the balance, which would have been due, the CONTRACTOR shall not have claim to the difference.

15.3 Termination of Contract by City (For Convenience)

- A. The CITY may terminate the Contract at any time if it is found that reasons beyond the control of either the CITY or CONTRACTOR make it impossible or against the CITY'S interests to complete the WORK. In such a case, the CONTRACTOR shall have no claims against the CITY except: (1) for the value of work performed up to the date the Contract is terminated; and, (2) for the cost of materials and equipment on hand, in transit, or on definite commitment, as of the date the Contract is terminated, which would be needed in the WORK and which meet the requirements of the Construction Documents. The value of work performed and the cost of materials and equipment delivered to the site, as mentioned above, shall be determined by the CITY'S REPRESENTATIVE in accordance with the procedure prescribed for the making of the final application for payment and payment under Paragraphs 14.8 and 14.9.

15.4 Termination of Contract by Contractor

- A. The CONTRACTOR may terminate the Contract upon 10 days written notice to the CITY, whenever: (1) the WORK has been suspended under the provisions of Paragraph 15.1, herein, for more than 90 consecutive days through no fault or negligence of the CONTRACTOR, and notice to resume work or to terminate the Contract has not been received from the CITY within this time period; or, (2) the CITY should fail to pay the CONTRACTOR any monies due him in accordance with the terms of the Construction Documents and within 60 days after presentation to the CITY by the CONTRACTOR of a request therefore, unless within said 10-day period the CITY shall have remedied the condition upon which the payment delay was based. In the event of such termination, the CONTRACTOR shall have no claims against the CITY except for those claims specifically enumerated in Paragraph 15.3, herein, and as determined in accordance with the requirements of said paragraph.

ARTICLE 16 -- MISCELLANEOUS

16.1 Giving Notice

- A. Whenever any provision of the Construction Documents requires the giving of written notice, it will be deemed to have been validly given if delivered in person to the individual or to a member of the firm or to an officer of the corporation for whom it is intended, or if delivered at or sent by registered or certified mail, postage prepaid, to the last business address known to the giver of the notice.

16.2 Title to Materials Found On the Work

- A. The CITY reserves the right to retain title to all soils, stone, sand, gravel, and other materials developed and obtained from excavations and other operations connected with

SECTION 00700

the WORK. Unless otherwise specified in the Construction Documents, neither the CONTRACTOR nor any subcontractor shall have any right, title, or interest in or to any such materials. The CONTRACTOR will be permitted to use in the WORK, without charge, any such materials, which meet the requirements of the Construction Documents.

16.3 Right to Audit

- A. If the CONTRACTOR submits a claim to the CITY for additional compensation, the CITY shall have the right, as a condition to considering the claim, and as a basis for evaluation of the claim, and until the claim has been settled, to audit the CONTRACTOR'S books to the extent they are relevant. This right shall include the right to examine books, records, documents, and other evidence and accounting procedures and practices, sufficient to discover and verify all direct and indirect costs of whatever nature claimed to have been incurred or anticipated to be incurred and for which the claim has been submitted. The right to audit shall include the right to inspect the CONTRACTOR'S plants, or such parts thereof, as may be or have been engaged in the performance of the WORK. The CONTRACTOR further agrees that the right to audit encompasses all subcontracts and is binding upon subcontractors. The rights to examine and inspect herein provided for shall be exercisable through such representatives as the CITY deems desirable during the CONTRACTOR'S normal business hours at the office of the CONTRACTOR.

The CONTRACTOR shall make available to the CITY for auditing, all relevant accounting records and documents, and other financial data, and upon request, shall submit true copies of requested records to the CITY.

(END OF SECTION)

SECTION 00800

WELL 7 PUMP HOUSE IMPROVEMENTS, CIP PW 23-05
CUPCCAA INFORMAL BID SOLICITATION

SUPPLEMENTARY CONDITIONS

SUPPLEMENTARY CONDITIONS

SC-1 GENERAL

These Supplementary Conditions make additions, deletions, or revisions to the General Conditions as indicated herein. All provisions which are not so added, deleted, or revised remain in full force and effect. Terms used in these Supplementary Conditions which are defined in the General Conditions have the meanings assigned to them in the General Conditions.

SC-2 DUTIES, RESPONSIBILITIES AND LIMITATIONS OF AUTHORITY OF CITY'S REPRESENTATIVE

The City's Senior Construction Manager shall be the designated CITY'S REPRESENTATIVE for the Project. The CITY'S REPRESENTATIVE shall act as directed by and under the supervision of the CITY and will confer with the CITY regarding its actions. The CITY'S REPRESENTATIVE'S dealings in matters pertaining to the on-site WORK shall, in general, be only with the ENGINEER, and the CONTRACTOR, and dealings with subcontractors shall only be through or with the full knowledge of the CONTRACTOR. Written communication by the CONTRACTOR with the CITY will be only through or as directed by the CITY'S REPRESENTATIVE.

SC-3 COORDINATION WITH OTHER CONTRACTORS

A. Coordination

Due to the nature of the work and its effects on other contracts and/or contractors in this project, the Contractor shall coordinate all work with the Engineer, other Contractors and utility companies.

SC-4 HOURS OF WORK

N/A

SC-5 CITY-FURNISHED MATERIALS

N/A

SC-6 PHYSICAL CONDITIONS – Subsurface and Existing Structures

A. Explorations & Reports - N/A

B. Existing Structures - N/A

SC-7 PHYSICAL CONDITIONS – Underground Utilities

A. Shown or Indicated - N/A

B. Not Shown or Indicated - N/A

SECTION 00800

WELL 7 PUMP HOUSE IMPROVEMENTS, CIP PW 23-05
CUPCCAA INFORMAL BID SOLICITATION

SUPPLEMENTARY CONDITIONS

SC-8 BONDS

N/A

SC-9 INSURANCE

N/A

SC-10 SUBCONTRACTOR'S INSURANCE REQUIREMENTS

N/A

SC-11 BUILDER'S RISK INSURANCE

N/A

SC-12 PERMITS

N/A

SC-13 COORDINATION OF PARTIES

N/A

SC-14 EQUIPMENT

N/A

SC-15 INCLEMENT WEATHER DELAYS

N/A

SC-16 TESTS AND INSPECTION, OUTSIDE AGENCIES

N/A

SC-17 TESTS AND INSPECTION, CITY OF LATHROP

N/A

SC-18 APPLICATION FOR PROGRESS PAYMENT

N/A

(END OF SECTION)

ATTACHMENT A



City of Lathrop
Department of Public Works

Approved By: Ken Reed DATE: 3-10-23
SENIOR CONSTRUCTION MANAGER

City of Lathrop
Department of Public Works

Approved By: [Signature] DATE: 3/9/2023
CITY ENGINEER RCE#: C92823
EXP: 12/31/2023

City of Lathrop
Department of Public Works

Approved By: [Signature] DATE: 3-10-2023
PUBLIC WORKS DIRECTOR

Improvement Plans

**Well 7 Pump House Improvements
PW 23-05**

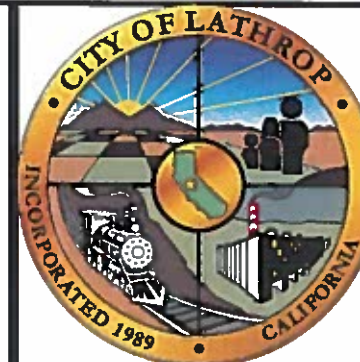

**Department of Public Works
City of Lathrop**

Drawn By: T.M.
Checked by: S.H.
Project Manager: K.R.
Date: February 2023

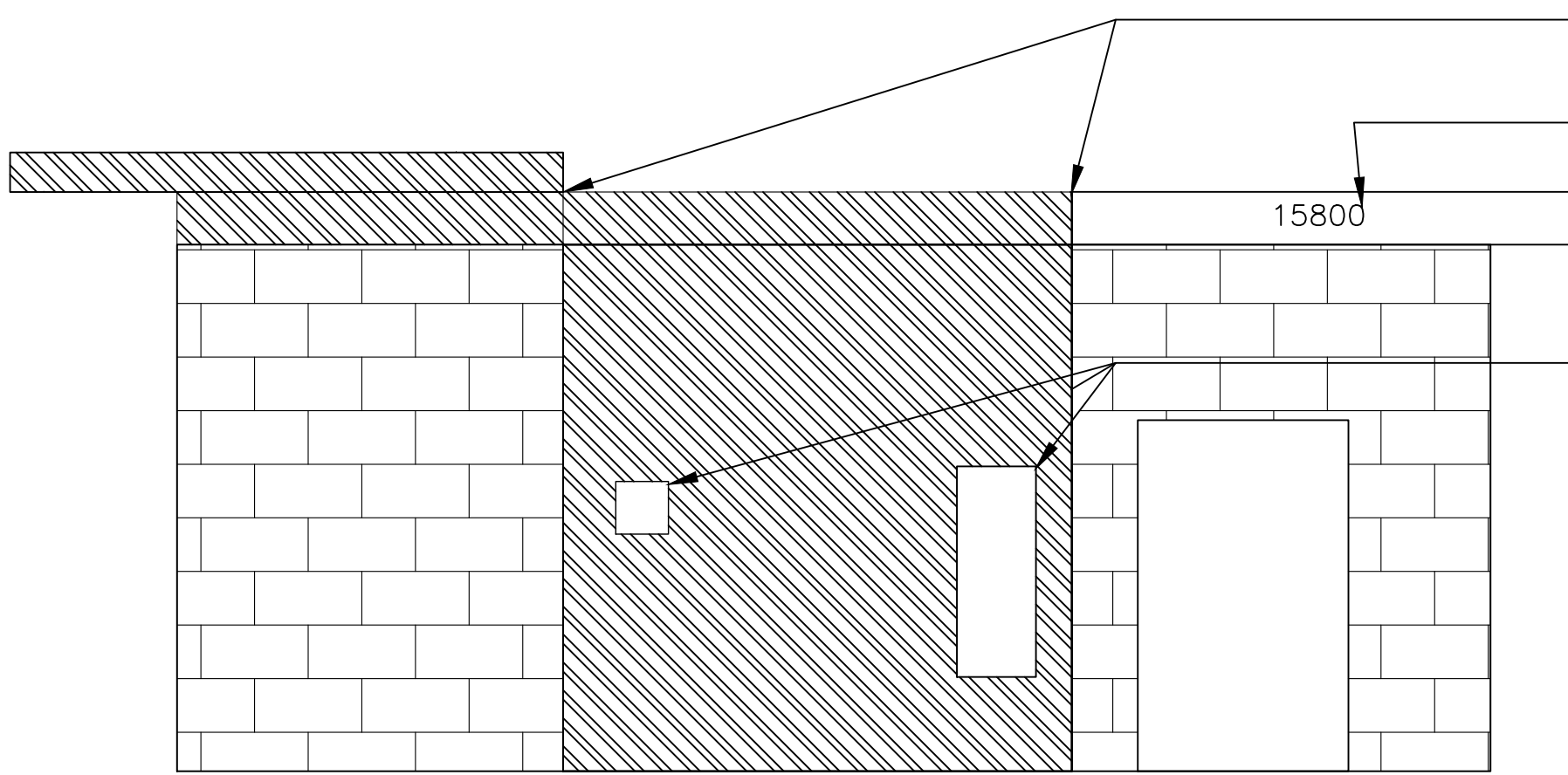

CMU to be sawcut and removed, existing roof to be replaced.

Replace address numbers with 1/2" x 8" Aluminum numbers

Remove and dispose of existing wall, return vent and mounted box to City.

West Profile

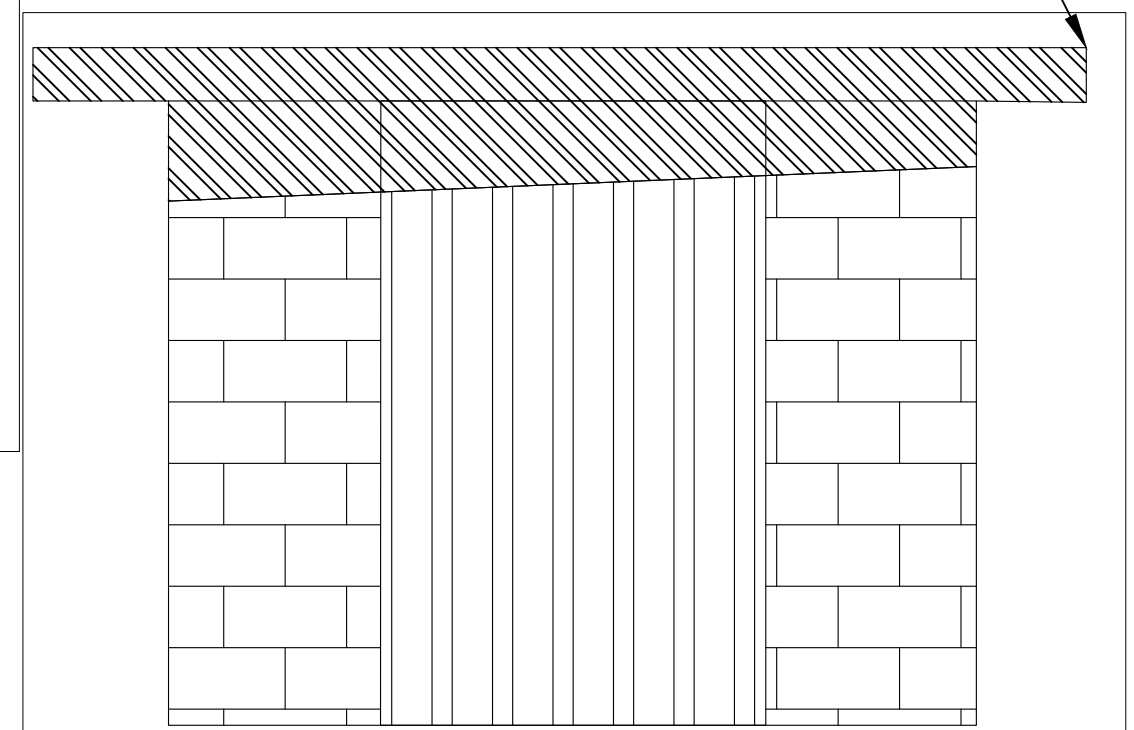

North Profile

1. Existing areas shaded to be removed, as well as all materials currently attached to them.
2. Chainlink fencing attached to building to be removed and disposed of per spec.
3. Remove and replace hatch segment (see sheet 3).

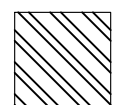

Remove and dispose of existing.

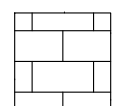

CMU Block to remain.

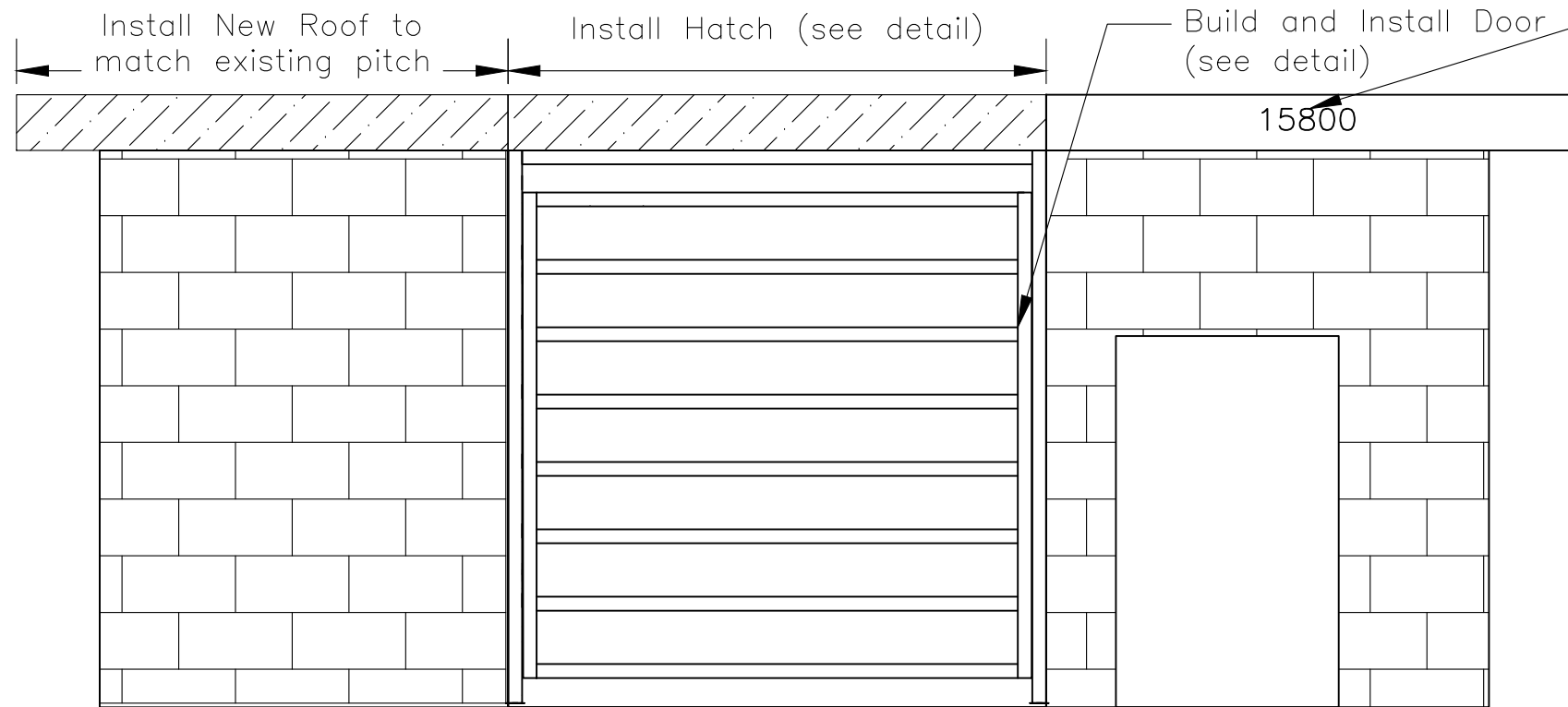

West Profile

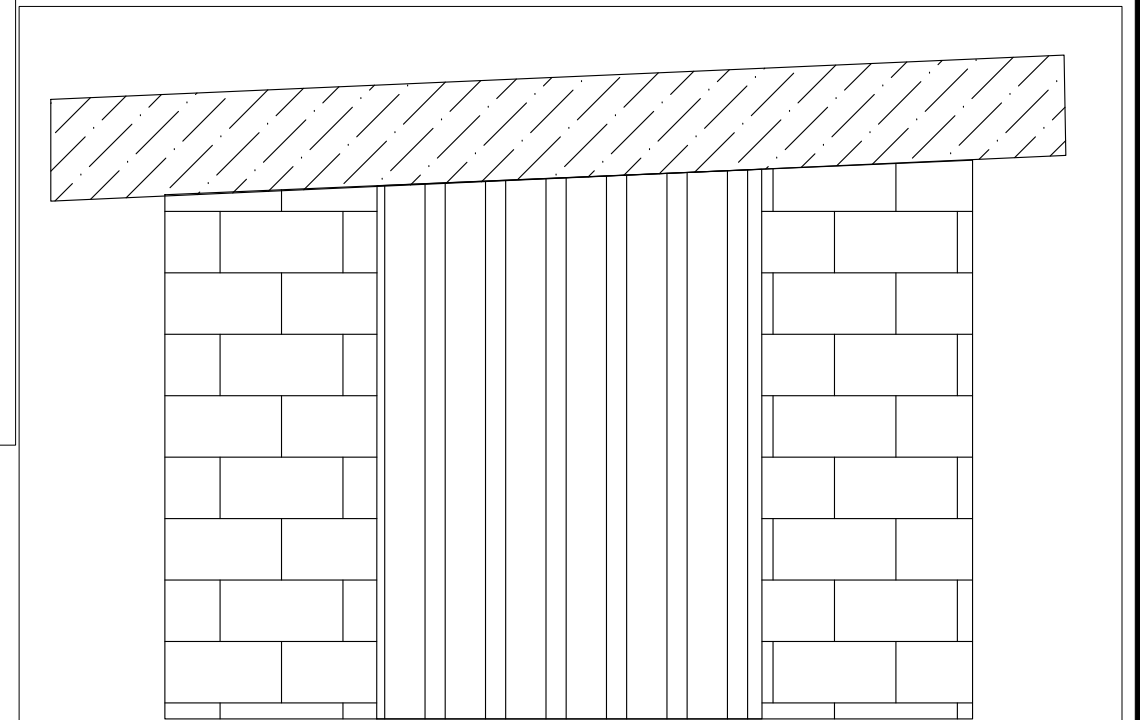

North Profile

1. New Roof section to match existing section on opposite building side.
2. All existing signage to be replaced with new items.
3. Roof surface to be standing seam metal sheeting.
4. Replace existing wall with swing door (see detail Sheet 5), bottom to be less than 1" from slab.
5. All dimensions provided for reference only, actual structure to be fit in field to existing.

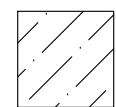

New Roof/Hatch segments to detail.

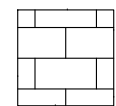

CMU Block to remain.

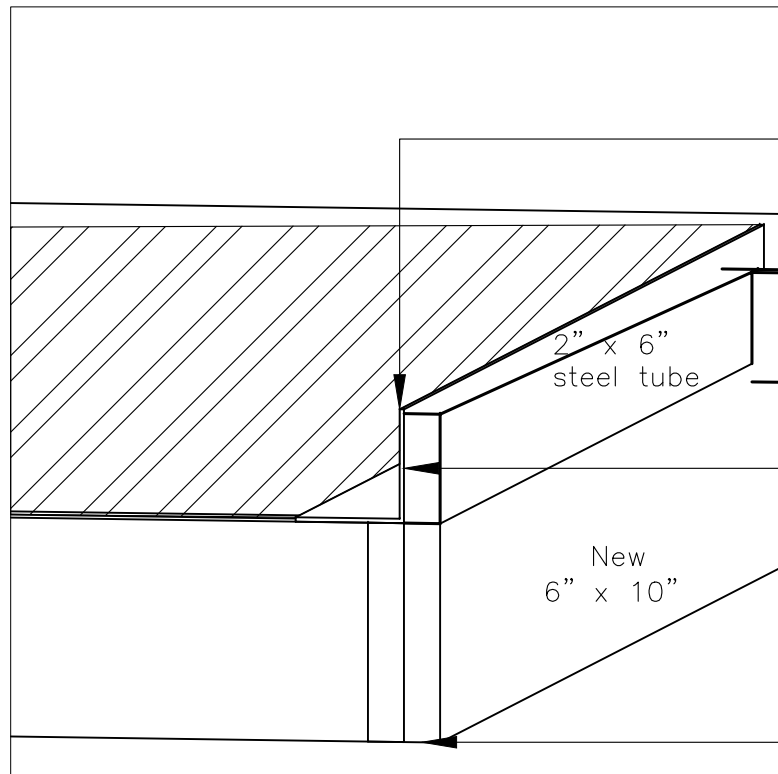

Detail 1
Hatch interface section

6"x6" L Sheet Metal w FLush Screens 6" OC at top of vertical leg

2" x 6" steel tube

Butyl Caulking between roof panel and L

New 6" x 10"

2" x 6" all spans

DF#2 or better

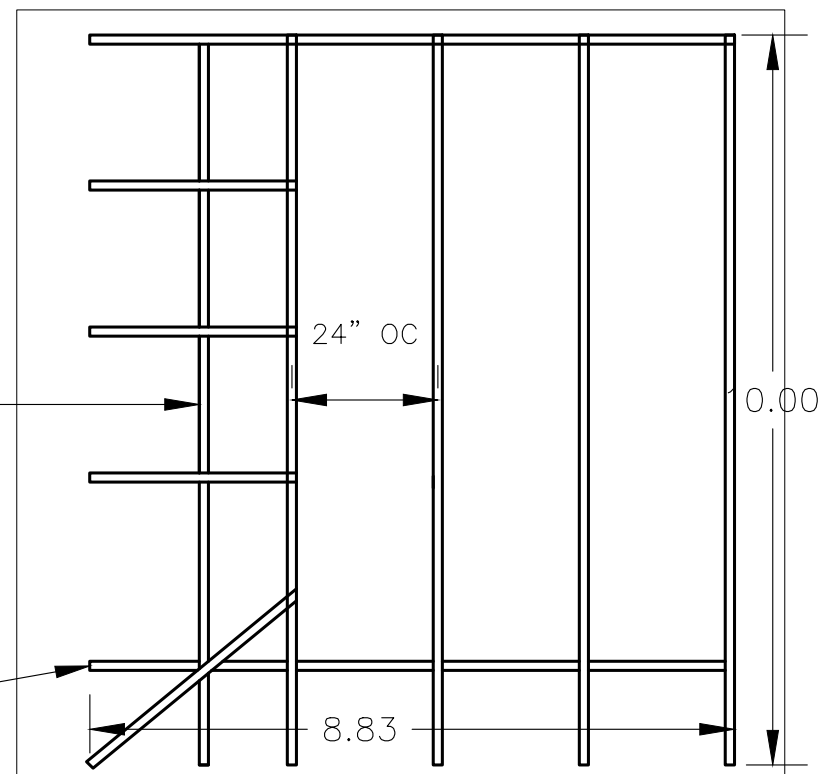

Detail 3
Fixed Roof Layout

24" OC

8.83

10.00

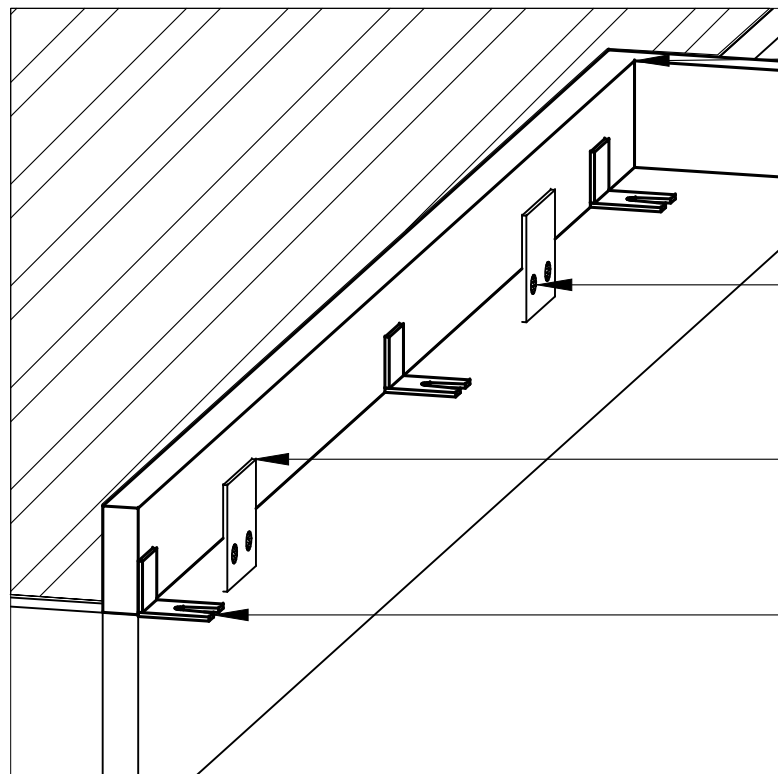

Detail 2
Roof attachment detail

Full Welded Corner (typ.)

2 - 1/2" x 3" Lags per strap

Weld on 3" x 6" Straps w/ 2 5/8" holes (typ. 2 per side)

3" x 3" x 4" Wide Angle Iron, slotted to accept All-Thread 3 per side

2" x 6" Rectangular steel tubing (exterior 4 sides)

2" x 3" Lifting Eye w/ 1" Hole (see detail)

2" x 4" Rectangular steel tubing (all center spans)

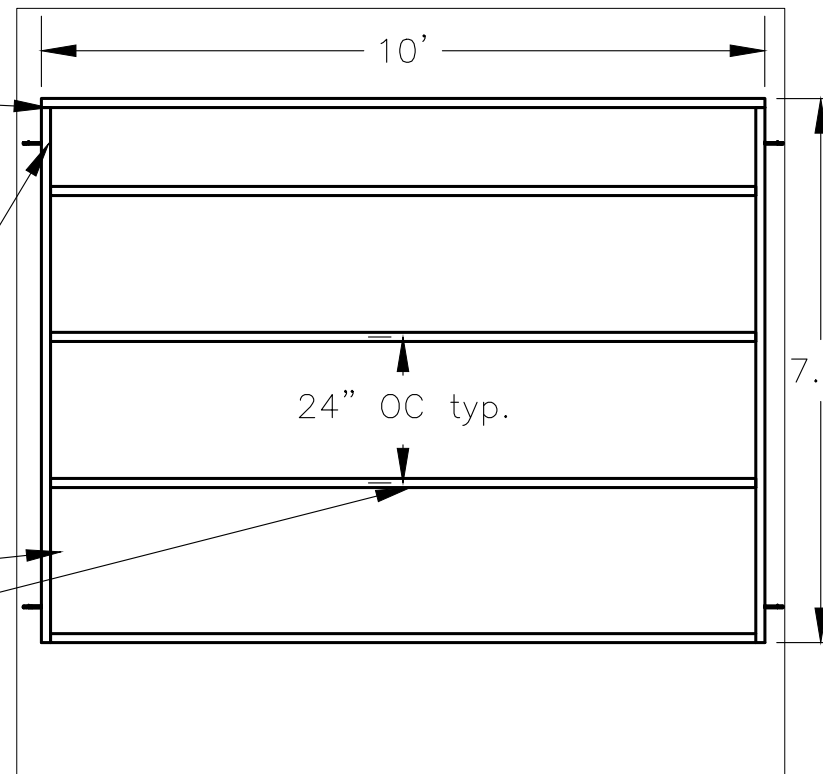

Detail 4
Hatch layout

10'

24" OC typ.

7.5'

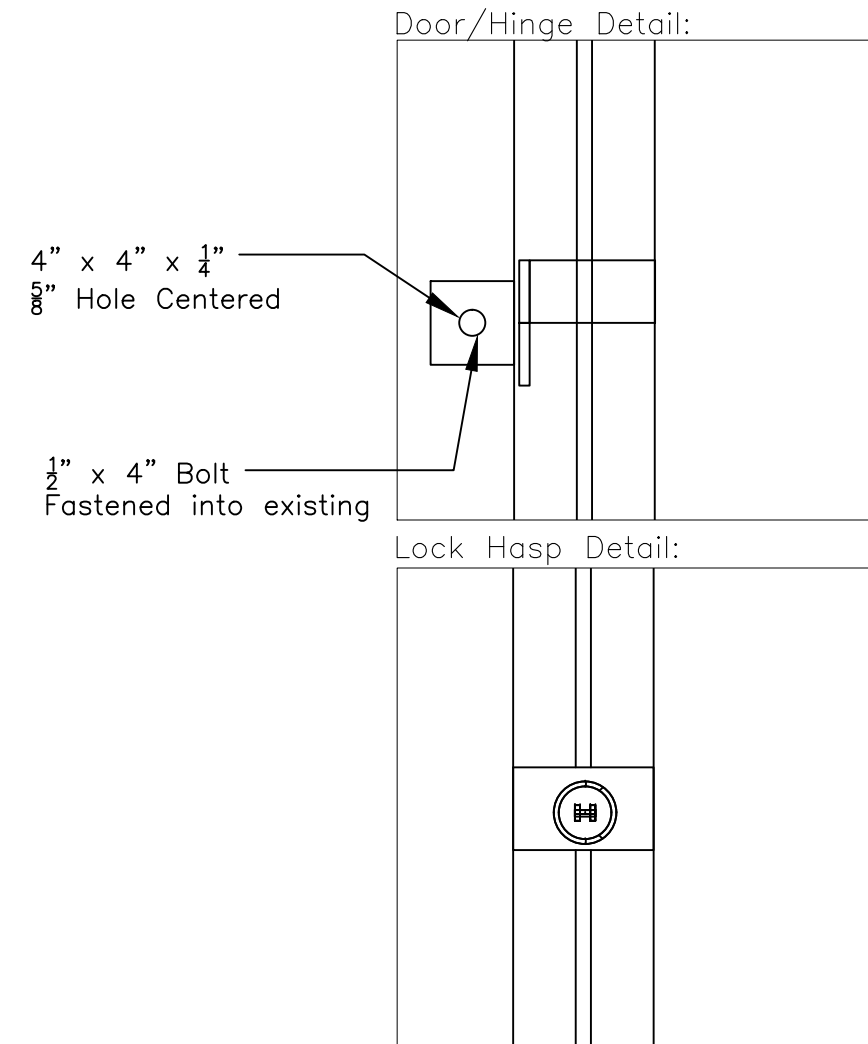
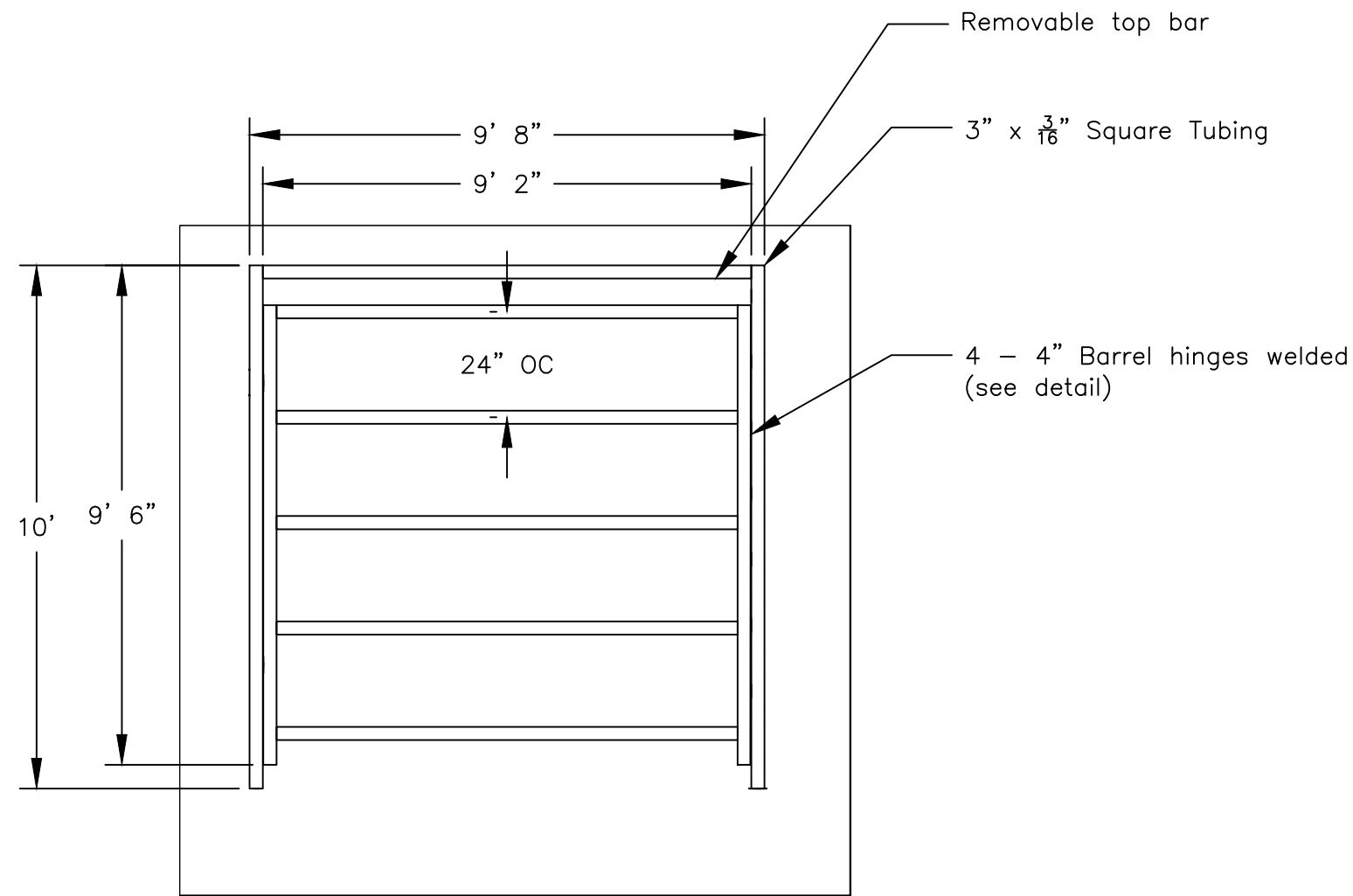

Notes:

1. 6 attachment points fastening frame to existing structure, 2 per each side and 1 attaching to floor per side.
2. All welds to be ground flush, sanded and painted w/ 1 coat Red Oxide Primer, and 2 coats industrial grade black semi-gloss.
3. Door to be covered with 10ga. steel, primer and painted w/ DTM and skip welded to frame 1" x 12"

Tie Down Detail

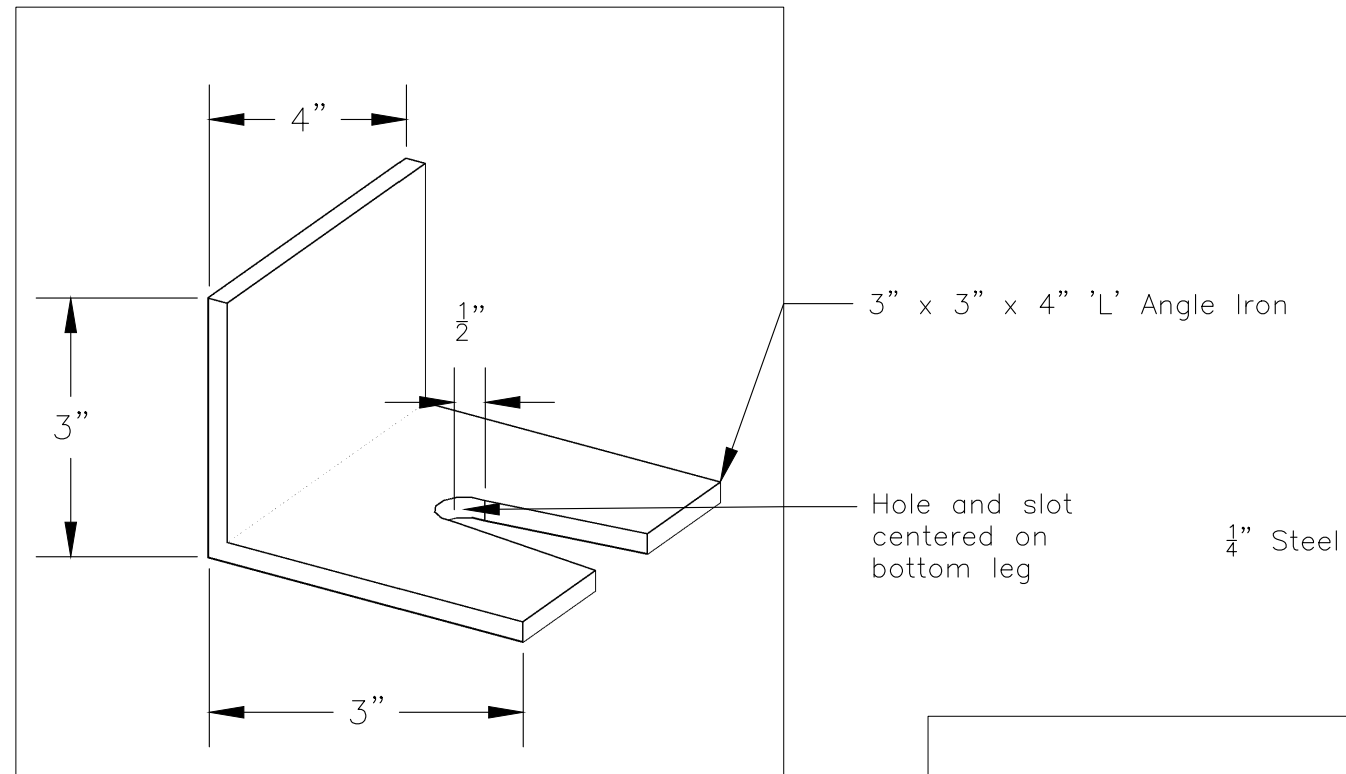

1. 3 ea. welded to hatch and attachment rails, two sides (12 total)
2. All welds to be ground flush, sanded and painted w/ 1 coat Red Oxide Primer, and 2 coats industrial grade semi-gloss.

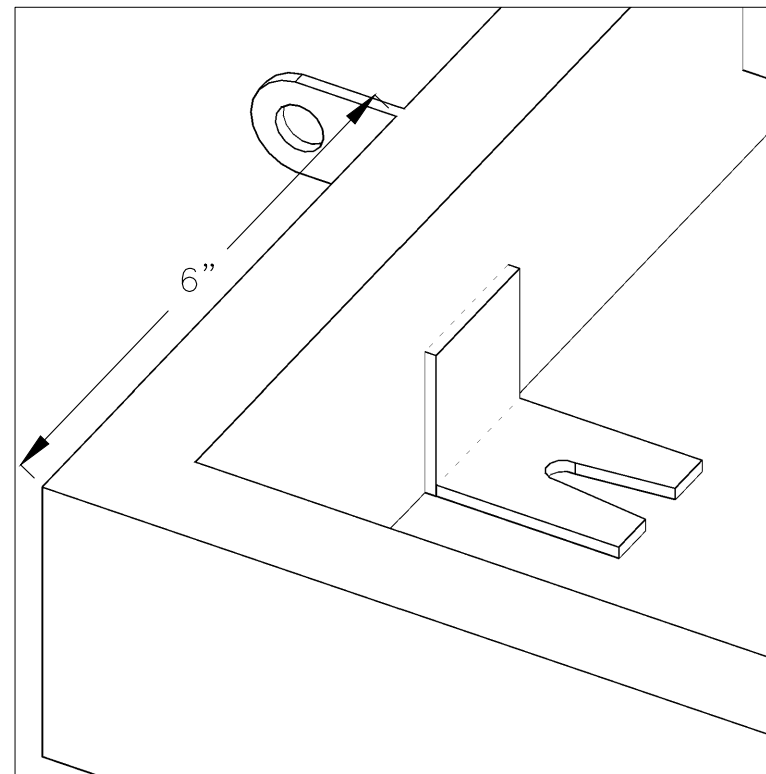

Lifting Eye Detail

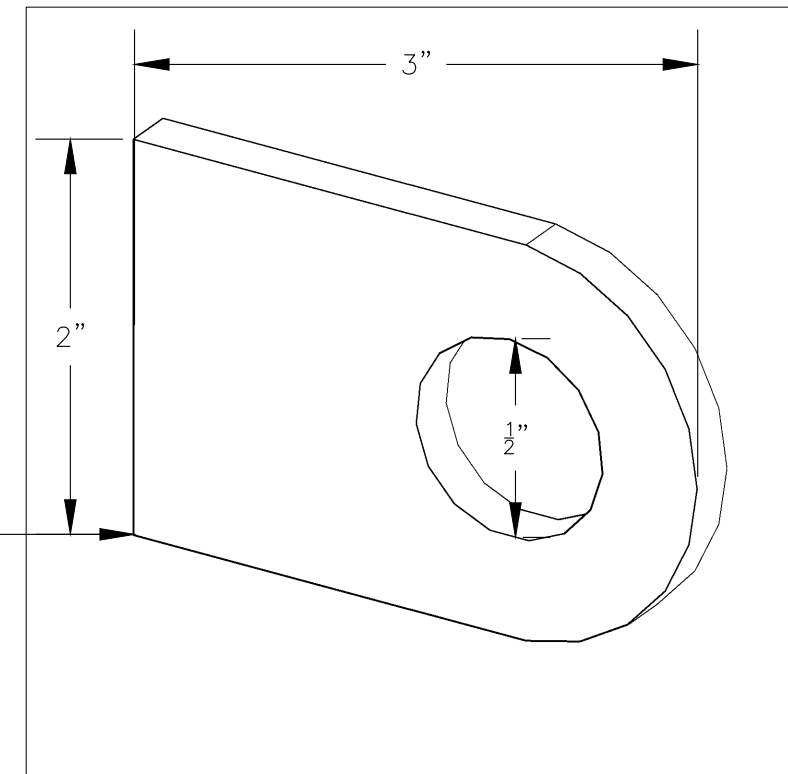

1. 4 ea. welded to hatch, 6" from nearest edge on sides.
2. All welds to be ground flush, sanded and painted w/ 1 coat Red Oxide Primer, and 2 coats industrial grade semi-gloss.

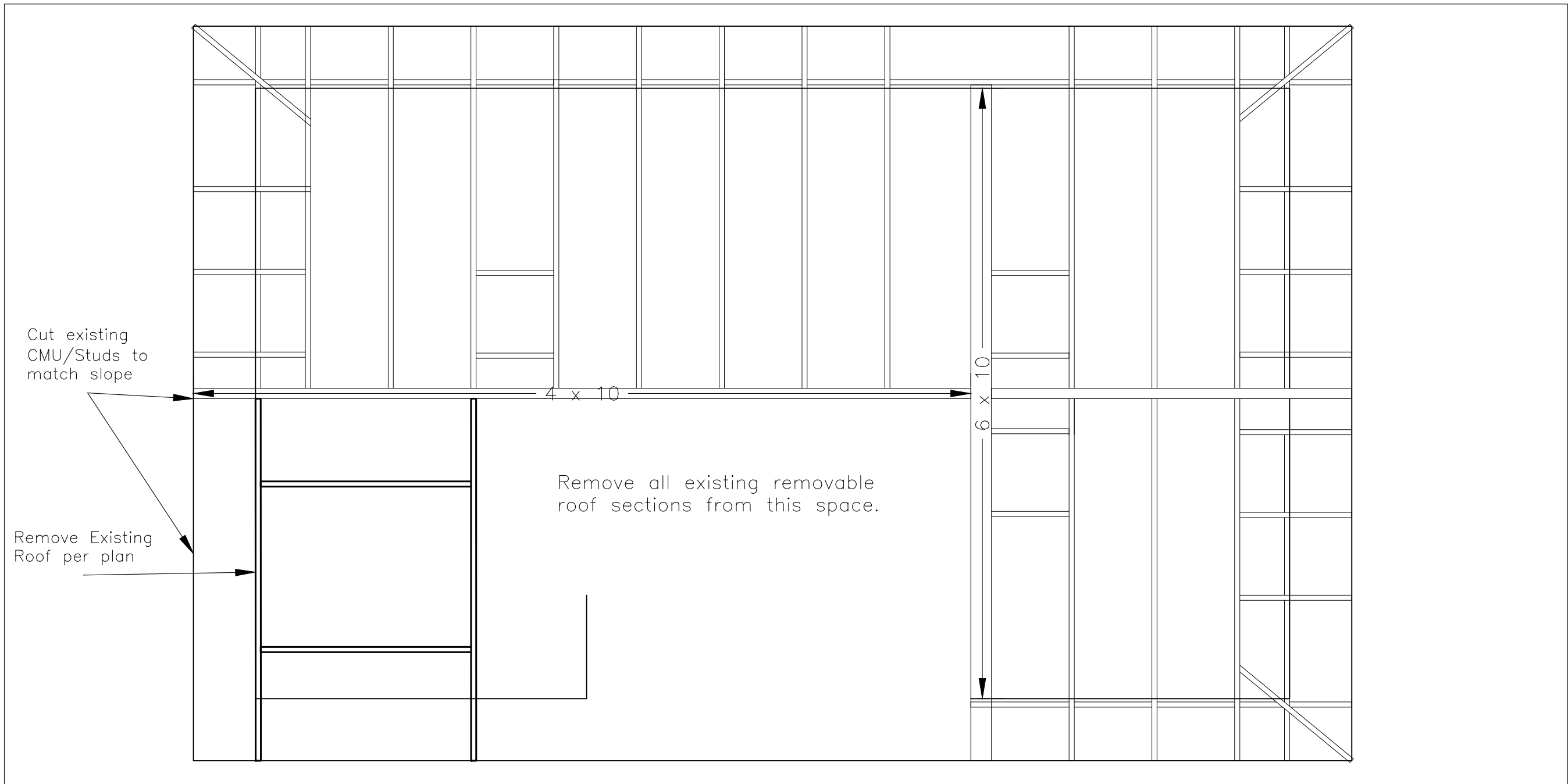

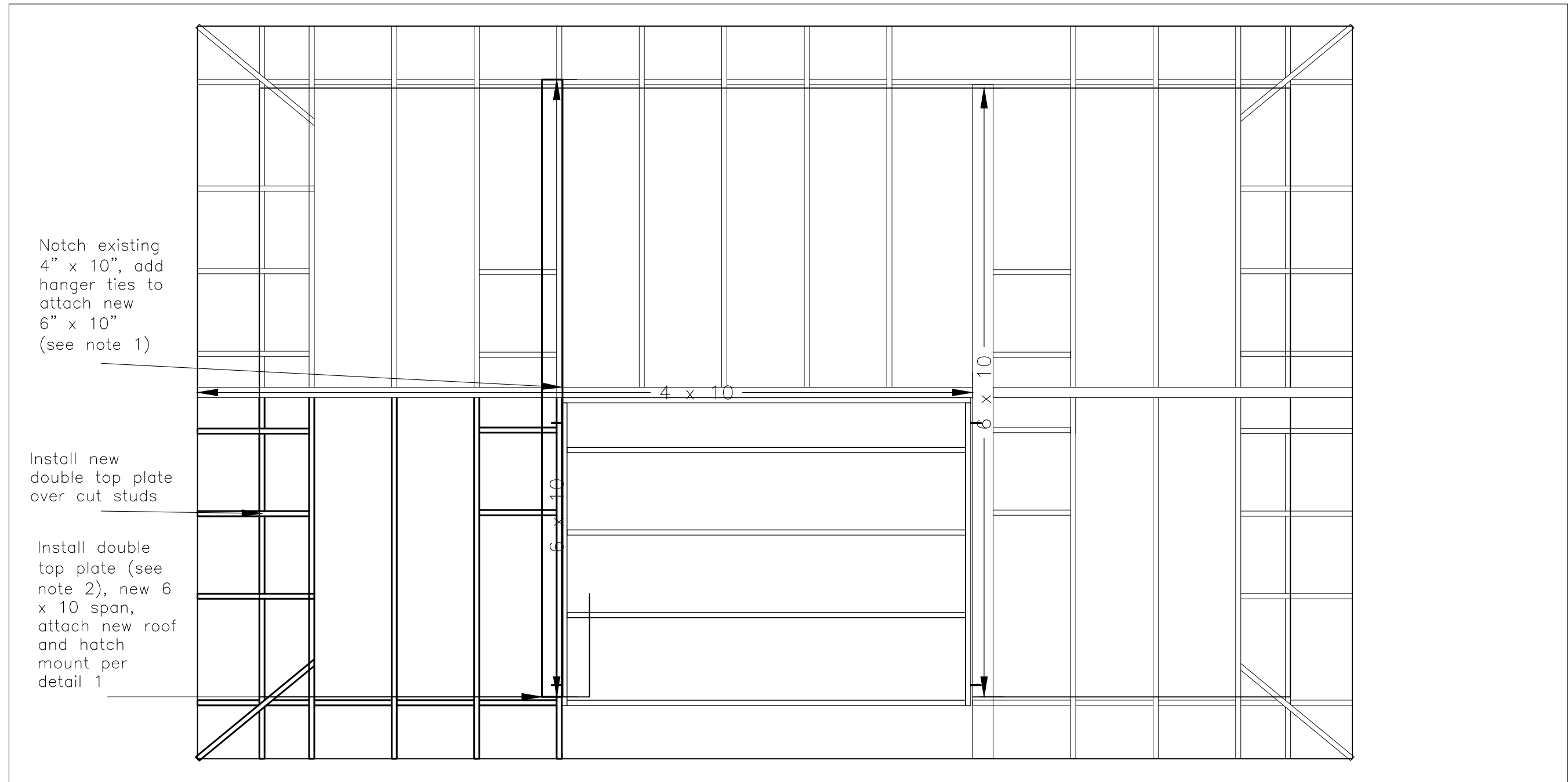

1. Hanger ties Simpson IUS 3.56-9.5 or approved equal.
2. Rafter to top plate ties Simpson H2.5 or approved equal.
3. SD #9 x 1 ¹/₂" screws to secure ties.

ATTACHMENT B

WELL 7 PUMP HOUSE IMPROVEMENTS - CIP PW 23-05

TECHNICAL SPECIFICATIONS

1. Removal / Demolition / Offhaul / Disposal of Materials

a. Items Covered

- i. existing roof – all hardware, flashing, wood, other roof debris and unsalvageable corrugated steel panels from sections scheduled for removal on Project Plans, including existing elevated roof, existing removable roof section, and all roof debris from repairs to existing roof.
- ii. existing roof – corrugated steel panels in acceptable condition will be retained by the City at Senior Construction Manager’s discretion.
- iii. existing wall sections: all framing, CMUs, hardware and debris from demolition of western portion of north wall and northern portion of west wall to accommodate new roof sections.
- iv. existing double doors – all framing, doors / siding and associated hardware
- v. existing chain link fencing- all chain link fence fabric and associated posts, rails, gate, post hole concrete and hardware. Contractor shall backfill and manually compact post holes.
- vi. Antenna conduit: 2” steel pipe shall be removed at service panel inside building; install 2” IPT plug. Repair hole in roof; return pipe to City.
- vii. Miscellaneous
 1. Remove exterior control box, return to City.

b. Method – Contractor shall carefully remove from the existing structure, offhaul and dispose of in an approved manner all materials designated in the Project Plans for removal.

c. Payment – Payment for “Removal, Offhaul and Disposal” of building materials and chain link fencing shall be a Lump Sum, and shall include all costs for the demolition / removal, transportation offsite and disposal fees, and no further payment for this item will be allowed.

ATTACHMENT B

2. Roofing Repair / Replacement

- a. Fixed roof replacement
 - i. Structure – framing shall match existing rafter dimensions, overhang and spacing, joist hangers, D.F. S4S lumber.
 - ii. Trim – Trim shall match existing fascia and soffit dimensions.
- b. Hatch replacement
 - i. Hatch framing shall be steel framing per plan.
 - ii. Hatch framing shall be welded in place to proper dimensions and powder-coated offsite.
- c. Roof and Hatch Construction
 - i. Roof sheathing – All roof sheathing to be ¾” CDX plywood
 - ii. Moisture barrier- Tyvek Protec 120 or approved equal.
 - iii. Hatch and roof surface shall be 22 ga. steel standing seam panels at 16” width. City will determine color.
 - iv. All bolts, nuts and washers to be hot dip galvanized steel.
- d. Payment: Payment for roof / structure bid items shall be as follows:
 - i. Repair Existing Roof Damage as Needed – Replacement of all damaged sheathing and moisture barrier on existing roof sections to remain in place
 - ii. Construct New Roof Section to Match Existing- All materials, hardware, and labor to construct framing and roof.
 - iii. Moisture Barrier – Moisture barrier and install for all new roofed sections.
 - iv. Construct / Install 8’-9” x 10’ Removable Hatch – Steel framing – Complete construction of hatch including lifting eyelets and all hardware required for assembly.
 - v. Install Standing Seam Roof Panels – All metal roof panels needed to cover entire structure.

ATTACHMENT B

3. Well Access Door

a. Materials

- i. Framing and Siding: Construct per Plans.
- ii. Hinges: Hinges shall be barrel-type, 700 lb. min. capacity, with weldable steel plates on both halves and a Zerc fitting.
- iii. Hasp and Lock: Hasp to be Master Lock model #770 or approved equal, and lock to be Master Lock model #6271 or approved equal

- b. Payment: Payment for this Lump Sum item shall include steel framing and sheet metal panel, hinges, angle iron hinge mounts, hasp and padlock and all labor and miscellaneous hardware necessary for construction.

4. North Wall Exterior Siding

- a. Siding shall be Hardie Smooth Plank Lap Fiber-Cement Siding - Primed or Approved Equal.
- b. Payment: Payment for this Lump Sum item shall include labor, siding, caulking and all hardware necessary for attachment of siding to existing structure.

5. Paint

a. Products

i. Types

1. Wood and Concrete masonry primer to be SW PrepRite ProBlock Int/Ext Latex Primer/Sealer White
2. Wood and Concrete masonry finish to be SW SPR EXT SA EXTRA
3. Metal primer to be SW PI PROCRYL PR OF W
4. Metal finish to be SW Pro Industrial DTM Acrylic Semi-Gloss Extra White
5. Tank / Pipes primer to be SW 2 part Macropoxy 646
6. Tank / Pipes finish to be SW SHER-LOXANE 800

ii. Colors

1. Paint color for Area 1 to be SW 7010 White Duck
2. Paint color for Area 2 to be SW 7046 Anonymous
3. Paint color for Area 3 to be SW 7045 Intellectual Gray
4. Paint color for Area 4 to be SW 7057 Satin Silver
5. Paint color for Area 5 to be SW 6958 Dynamic Blue
6. Paint color for Diesel Tank to be SW 4084 Safety Yellow
7. Paint color for interior walls to be SW 7057 Satin Silver

ATTACHMENT B

- b. Coverage:
 - i. All exterior surfaces of pump house except the roof shall be painted per painting plan, including: walls, roof soffit, fascia and flashing.
 - ii. All interior wall surfaces of the pump house shall be painted excluding sensitive equipment.
 - iii. Apply all primers and paints per manufacturer's instructions.
- c. Payment: Payment for this item shall be Lump Sum, and includes pressure washing to remove all loose material, caulking, 1 coat of primer and 1 finish coat of paint, and all clean-up.

ATTACHMENT C

WELL 7 PUMP HOUSE IMPROVEMENTS, CIP PW 23-05
CUPCCAA INFORMAL BID SOLICITATION

PAINING PLAN

PAINING PLAN – EAST ELEVATION



ATTACHMENT C

WELL 7 PUMP HOUSE IMPROVEMENTS, CIP PW 23-05
CUPCCAA INFORMAL BID SOLICITATION

PAINTING PLAN

PAINTING PLAN – NORTH ELEVATION

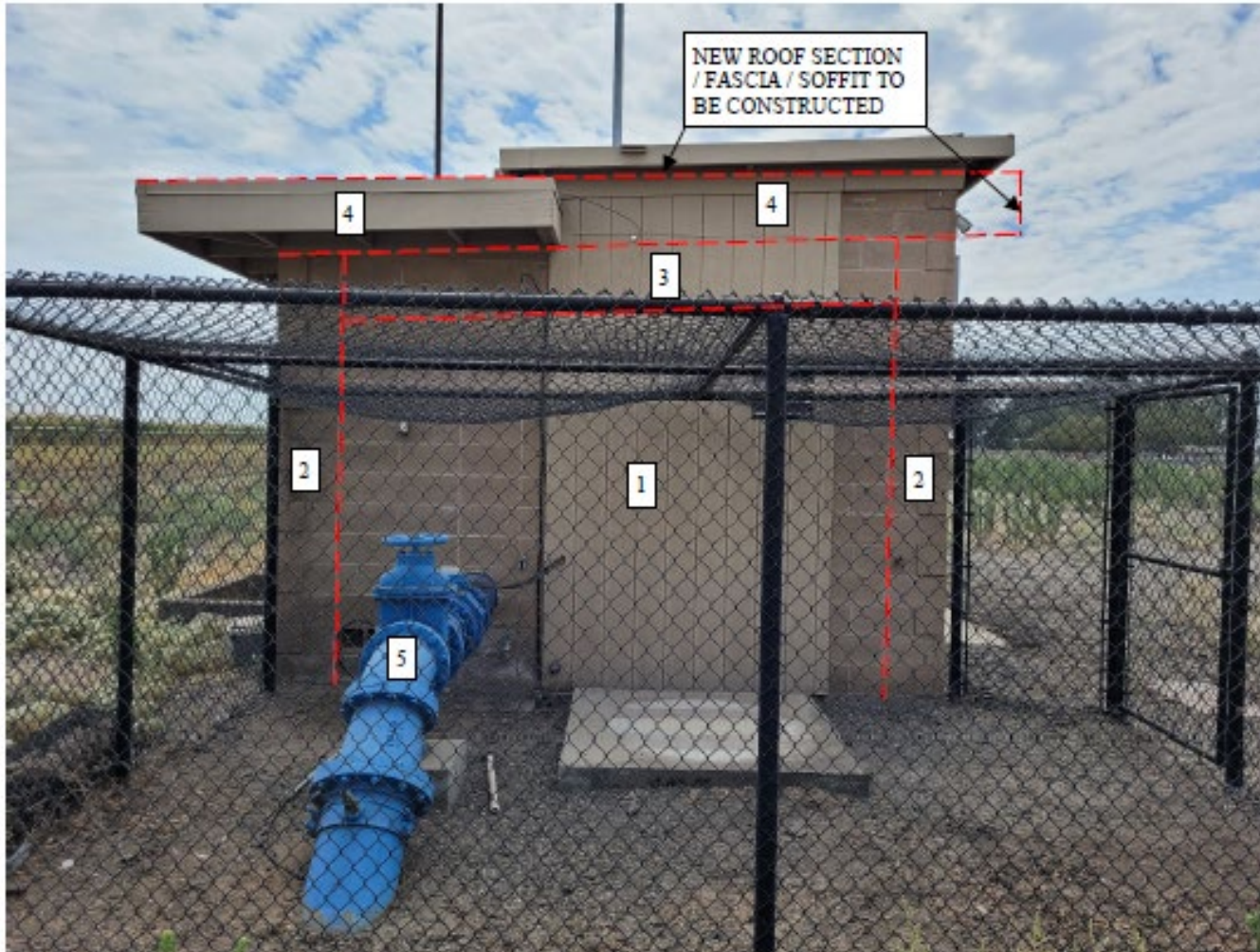

ATTACHMENT C

WELL 7 PUMP HOUSE IMPROVEMENTS, CIP PW 23-05
CUPCCAA INFORMAL BID SOLICITATION

PAINTING PLAN

PAINTING PLAN – SOUTH ELEVATION



ATTACHMENT C

WELL 7 PUMP HOUSE IMPROVEMENTS, CIP PW 23-05
CUPCCAA INFORMAL BID SOLICITATION

PAINTING PLAN

PAINTING PLAN – WEST ELEVATION



ATTACHMENT D

WELL 7 PUMP HOUSE IMPROVEMENTS, CIP PW 23-05
CUPCCAA INFORMAL BID SOLICITATION

PROJECT LOCATION MAP

